



GN ELECTRONICS
A division of Preferred Instruments



Quanta-Flame Self-check Scanner System

Model 5002-01 Ultraviolet
Model 5002-11 Infrared



USER MANUAL

Revised: June 11, 2007

31-35 South St., Danbury, CT 06810
Phone: (203) 743-6741 Fax: (203) 798-7313
www.gnelectronics.com



GN ELECTRONICS

A division of Preferred Instruments



FEATURES

- Internal microcomputer controls internal functions as well as supervising the relay contacts to verify they are always operating correctly.
- High quality fused silica quartz lens.
- Machined alloy housing with seals.
- Detectors and signal processor automatically checked every 10 seconds.
- Replacement scanner can be replaced without disturbing wiring.
- No scheduled replacement parts.
- Flame relay contacts and load circuit supervised
- Status LEDs
- Flame intensity
- Output on indicator
- Self-check indicator



The Quanta-Flame Series 5002 is intended for monitoring all gas, oil and coal-fired burners. The control is the basis for industrial or commercial burner management systems using microprocessors, PLC or relay-based hardware.

All essential circuits are supervised.

Two indicator LEDs indicate the status of the self-checking action, the flame proven output, and the flame intensity (variable LEDs).

Flame Status LED

The Flame Status LED (FSL) is a dual color LED that acts as a multi-functional indicator.

When a flame is detected the FSL will illuminate with a **red color**. This light will vary in intensity proportional to the level of flame signal (flame strength) detected.

Every 10 seconds the self-checking mechanism will interrupt the light coming from the flame. This is done in order to verify that the UV sensing element is still functioning properly. When this check is being performed the FSL will momentarily turn to a **yellow color (when flame present) or green color (when flame is not present)**.



GN ELECTRONICS

A division of Preferred Instruments



Should the UV sensing element fail to function, the scanner will lockout all the outputs to indicate the failure and the FSL will remain **green** without blinking for one minute.

After one minute the control will automatically reset itself. The scanner's microcomputer will then continue to check the sensing element every ten seconds. Should the sensing tube be in a permanent "runaway" condition then the scanner will immediately lockout again for another period of one minute.

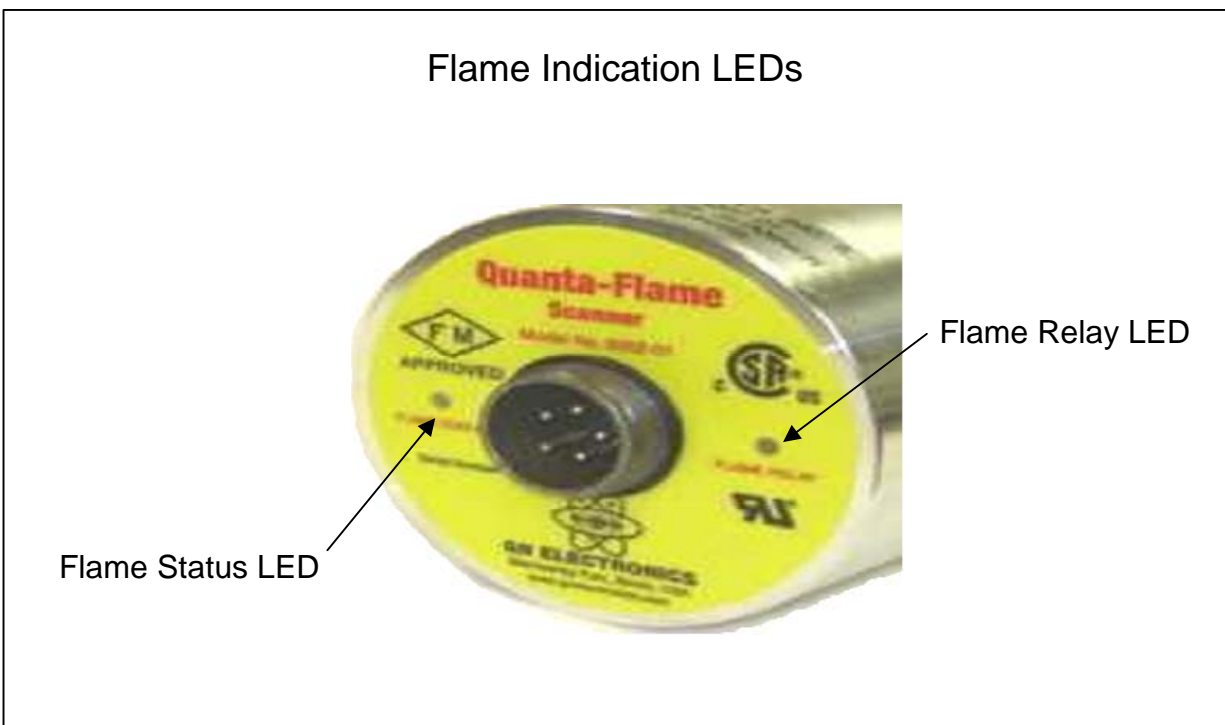

Flame Relay LED

The Flame Relay LED (FRL) is a single color LED.

When a flame of sufficient intensity is detected the 5002 control will activate the output signal. This output may be any one of the possible output forms described above. While the output is activated the FRL will illuminate. Should the flame signal fall below the minimum threshold, or should one of the internal circuits or sensing elements tests fail, the output will deactivate and the FRL will shut off.



GN ELECTRONICS

A division of Preferred Instruments



SPECIFICATIONS

MECHANICAL:

Length Overall: 7" (177.8 mm)
Diameter: 3.25" (82.5 mm)
Housing: Machined 5052 Aluminum Alloy
Finish: Clear Anodized
Sight Tube Entrance: 1" Pipe Thread
Purge Air Entrance: 3/8" Pipe Thread

ELECTRICAL:

Supply Voltage: 120 VAC 50/60Hz,
230 VAC 50/60Hz
24 VDC
(depending on model)
Required power: 2VA
Output Contact Rating: 230 VAC, 1 amp
Available Outputs: Relay Contact
4 to 20 ma
Frequency Modulation
(depending on model)
Specifications for 4 to 20 ma output (two-wire current loop)
Span error: 1%
Non-linearity: 0.1%
Supply required to the loop: 12 to 30 VDC

ENVIRONMENTAL:

Class: NEMA 4
Temperature: (0°F to 140°F).



GN ELECTRONICS

A division of Preferred Instruments



OPTICAL:

Lens Material: Fused Silica.

SPECTRAL SENSITIVITY:

Ultraviolet: 180-230 nanometers

Infrared: 320-1100 nanometers

PRODUCT CERTIFICATIONS:

Note: Product certification only for models below as indicated in table:

5002-01	Microcomputer controlled UV Scanner (120VAC) Relay & Flame Amplifier Output	FM / UL / CSA / CSAUS
5002-11	Microcomputer controlled IR Scanner (120VAC) Relay & Flame Amplifier Output	FM

UL file Number: E233069

CSA Certification: File No. 204571 –Project Number 1181621 and 1298906 update to add PCI and Eclipse controls. See attached CSA Certificate of Compliance

FM Approved Report Number: 3009512 and 3013648 (for use specifically with Eclipse Combustion Inc and Protection Controls Combustion Safeguards)

Applicable Requirements: CSA 0.8-M1986, 199-M89, UL 372, UL1998, FM Class 7610

Note: Handle with care. Internal sensing element may be damaged if scanner is dropped.



GN ELECTRONICS

A division of Preferred Instruments



ORDERING INFORMATION **UNITIZED UV SELF CHECK SCANNER**

Scanners

Catalog Number	Description
5002-01-120-0-00	Relay & flame amplifier output, 120 VAC, 1" NPT mount.
5002-01-024-0-00	Relay & flame amplifier output, 24 VDC, 1" NPT mount.
5002-01-240-0-00	Relay & flame amplifier output, 120 VAC, 1" NPT mount.
5002-01-120-C-00	Relay & 4-20 mA Flame Signal output, 120 VAC, 1" NPT mount.
5002-01-024-C-00	Relay & 4-20 mA Flame Signal output, 24 VDC, 1" NPT mount.
5002-01-240-C-00	Relay & 4-20 mA Flame Signal output, 240 VAC, 1" NPT mount.
5002-01-120-0-SS	Relay & flame amplifier output, 120 VAC, 1" NPT, mount, SS Housing
5002-01-024-0-SS	Relay & flame amplifier output, 24 VDC, 1" NPT mount, SS Housing
5002-01-240-0-SS	Relay & flame amplifier output, 120 VAC, 1" NPT mount, SS Housing
5002-01-120-C-SS	Relay & 4-20 mA Flame Signal output, 120 VAC, 1" NPT mount, Stainless Steel Housing
5002-01-024-C-SS	Relay & 4-20 mA Flame Signal output, 24 VDC, 1" NPT mount, Stainless Steel Housing
5002-01-240-C-SS	Relay & 4-20 mA Flame Signal output, 240 VAC, 1" NPT mount, Stainless Steel Housing
5002-01-SS	Unitized self-checking UV scanner with relay & flame amplifier output. 120 VAC. 1" NPT mount. Stainless steel housing.
5002-11	Unitized infrared scanner with relay & flame amplifier output. 120 VAC. 1" NPT mount.



GN ELECTRONICS

A division of Preferred Instruments



Scanner Accessories

Catalog Number	Delivery	Description	List Price	Discount
5002-EP	Stock	Heavy duty scanner housing	\$650	B
5002-EPSS	5-6 weeks	Heavy duty scanner housing. Stainless steel	\$2,000	B
5002-EPC	Stock	5000 & 5002 series terminal connector	\$65	B
5000-02/05	Stock	Scanner cable- 5 feet	\$41.50	B
5000-02/10	Stock	Scanner cable- 10 feet	\$83	B
5000-02/xx	1-2 days	Custom scanner cable length (xx in feet)	\$8.3/ft	B
5002-02/91	Stock	Adapter for 5602-91-7 cable (from a 5602-91 scanner) to the 5002-01	\$100	B
-wt	Stock	Water tight connector added to scanner cable	\$42	B
5000-01-00L	Stock	Replacement quartz lens for Mounting nipple (5000-01-00)	\$80	B
5000-73/74-SS	5-6 weeks	Swivel mount- 2" NPT x 1" NPTF -stainless steel	\$240	B
5000-475	Stock	Single piece nipple 1" NPT X 4" long with lens and purge connection	\$260	B
5000-01-00-SS	Stock	Mounting nipple for 5000-01 scanner including quartz lens. Stainless steel (1" NPT x 4" long)	\$240	B
5000-11-00-SS	Stock	Mounting nipple for 5000-11 scanner including lens. Stainless steel (1" NPT x 4" long)	\$240	B
5000-01-00A	Stock	Mounting nipple for 5000-01 scanner with inset quartz lens for higher pressure applications. Stainless steel	\$260	B
5000-01-04-CT	Stock	Mounting Nipple, 1" NPT x 4" long for Scanners with 1" MNPT mounting thread. Carbon teflon. Rated 450°F (for other sizes call factory)	\$175	B
5000-01UFL	Stock	5002 Scanner line filter	\$125	B



GN ELECTRONICS

A division of Preferred Instruments



Installation

Notes:

- All installation, wiring, or service activities must only be performed by knowledgeable and qualified technicians.
- All system wiring to and from the control and scanner should be run in accordance with the National Electrical Code and all local code requirements.
- Neutral must be grounded.
- This product is designed to work in a variety of applications and conditions, however some applications may not be applicable due to the presence of high electrical noise, lack of adequate ground connections, floating neutrals or other known or unknown conditions. It is therefore important to ensure proper system environment before installing these devices.
- Always route sensor signal wiring a sufficient distance away from any type of ignition or other high voltage wiring to avoid electrical noise interference. Each sensor wire must be run separate from all other wires including other sensors. In some cases shielded or coaxial cable may be required for long distances or high electrical interference environments. Each pair of sensor leads should be in their own shielded or coaxial pair.
- Always remove all power to the system before wiring and never connect or disconnect scanner when power is present.
- Choose a sighting location providing an unobstructed view of the flame under all firing conditions. UNDER NO CONDITIONS SHOULD THE SCANNER SEE IGNITOR SPARK.
- A scanner monitoring a pilot flame should be positioned so that no flame will be detected if the pilot flame is too small to reliably and safely light the main flame.
- In multiple burner furnaces, choose a sighting angle with the best possible view of the flame of interest and the poorest possible view of other flames in the furnace. The sighting pipe should be inclined slightly downward toward the furnace floor so that unburned particles will not fall, or moisture will not drain, into the scanner cavities.



GN ELECTRONICS

A division of Preferred Instruments



The actual attachment of the scanner to the burner can be varied to suit individual applications. The scanner when applied to multiple burner applications should always be attached to a 5000-73/74 swivel mount to assist in burner discrimination. The swivel mount has a 2" NPT male connection and connects to a 2" NPT coupling welded to the burner front plate. The use of the swivel mount is recommended on single burner applications. A 1" NPT nipple connects the scanner to the swivel ball joint.

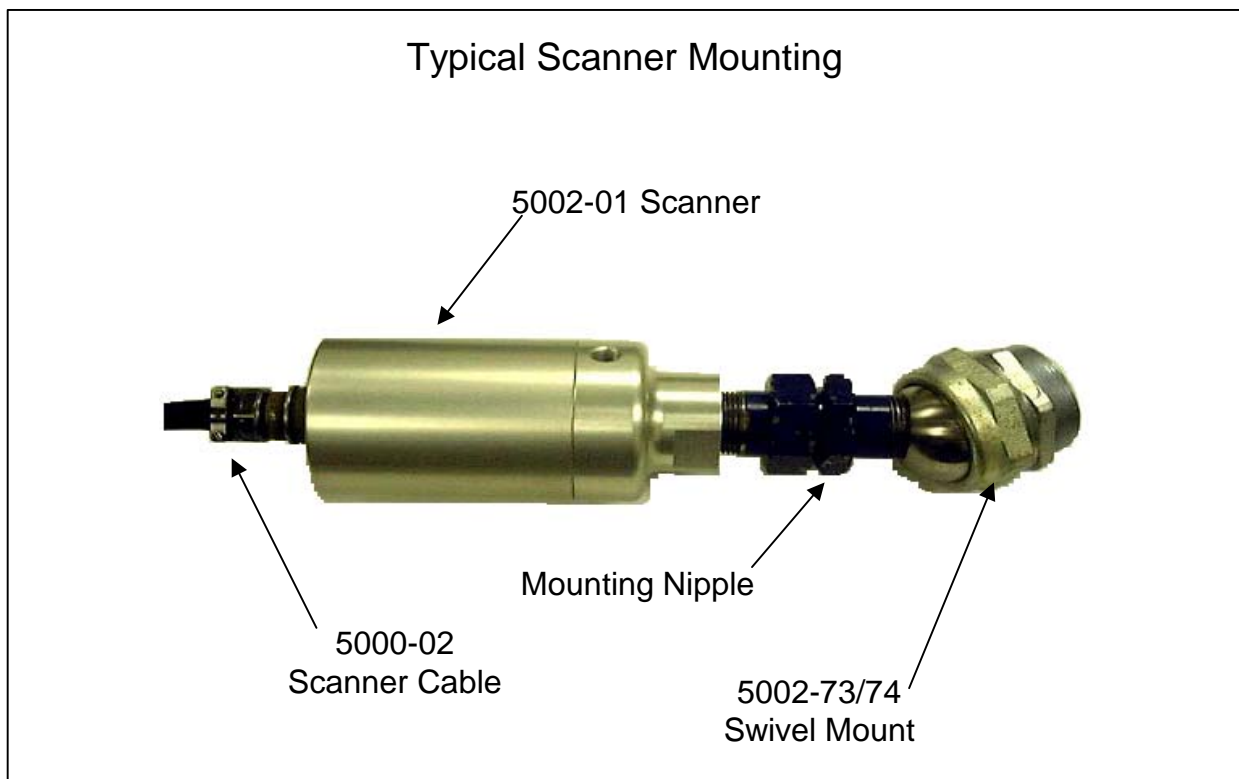

Installation and Operation Notes:

With the contact output option the internal contact is supervised by the microcomputer. If the scanner detects an absence of flame and the contact fails to open, a second fault relay will open the circuit and the scanner will lockout all the outputs. The Flame Status LED (FSL) will blink **(RED)** on for 3 seconds and off for 1 second. After one minute the scanner will reset itself and resume its normal functions. If the internal contact is permanently welded closed the scanner will lockout again for one minute at the next flame off condition.



GN ELECTRONICS

A division of Preferred Instruments



Note for use with some flame rod type controls: Some controls may generate large amounts of signal current through the 5002 scanner. This large current may need to be limited by a one Meg- Ohm resistor in series with the signal connection to pin E of the scanner. This will decrease the current to the control amplifier and reduce the possibility of signal saturation.

WIRING and CONNECTIONS

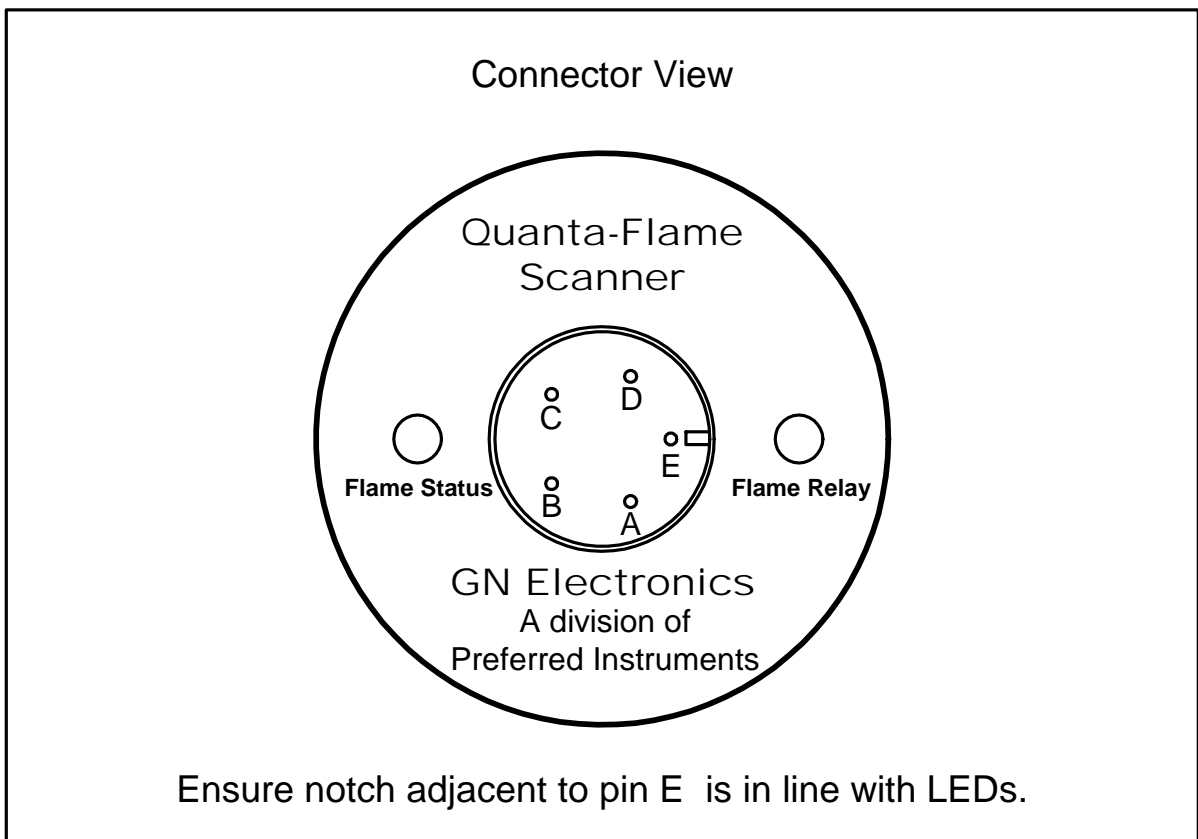

Note: Scanner cable colors on charts and diagrams below. For the pin “D” connection to the scanner some of the 5000-02 scanner cables will have a blue colored conductor and some will have a brown colored conductor.



GN ELECTRONICS

A division of Preferred Instruments



WIRING DIAGRAMS

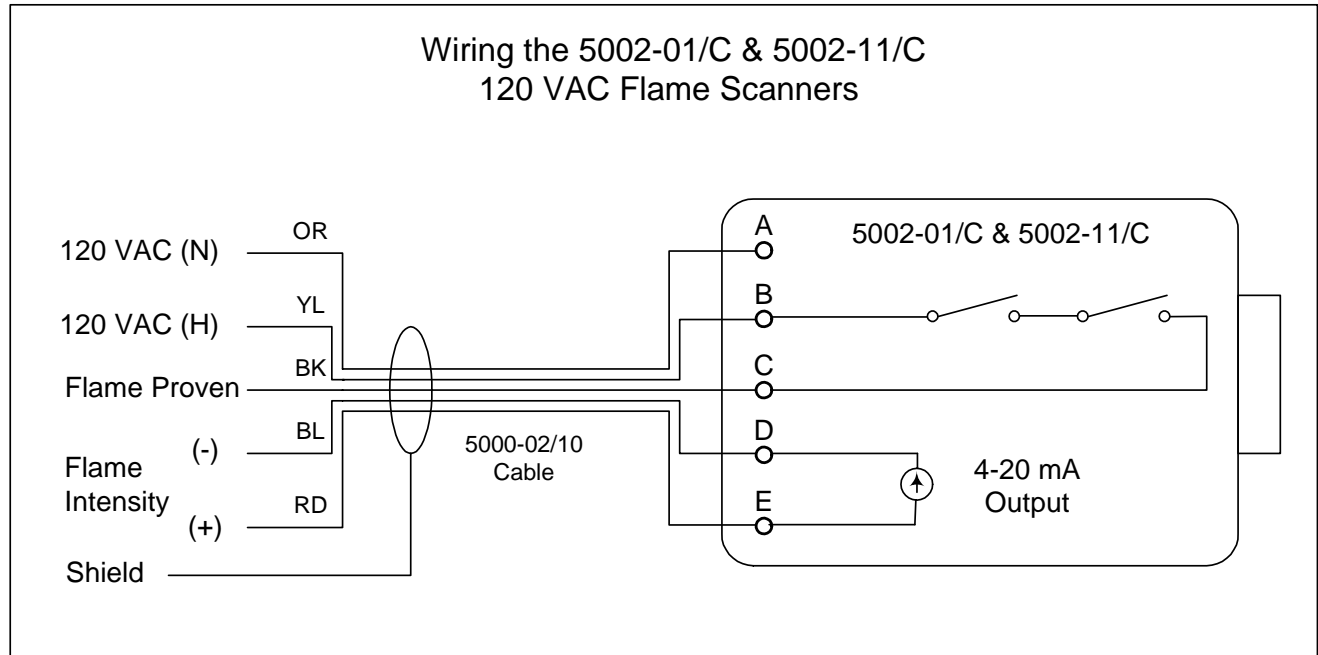

Notes:

1. Wiring shown for 120 VAC 50/60 Hz power supply.
2. Terminal C relay output terminal rating 1.0 amps.
3. Terminal D output contact rating 1.0 amps.
4. 5000-02/10 scanner cable available in custom lengths. Replace 5000-02/10 model number with 5000-02/xx. XX is in feet.



GN ELECTRONICS

A division of Preferred Instruments

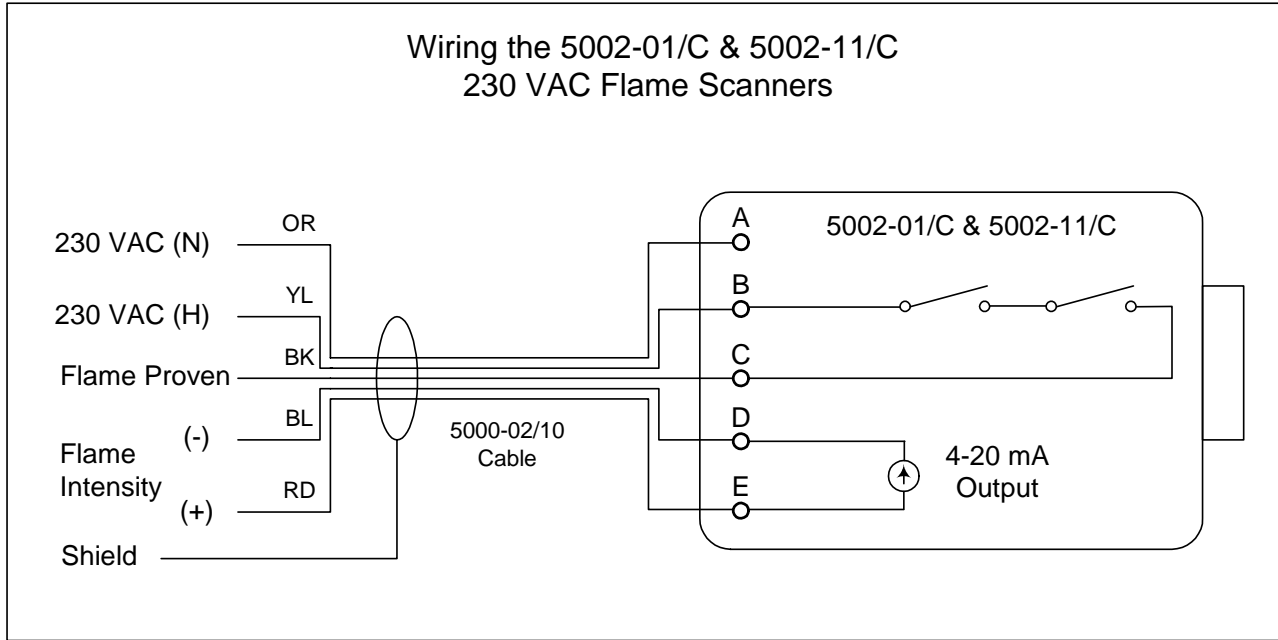

Notes:

1. Wiring shown for 230 VAC 50/60 Hz power supply.
2. Terminal C relay output terminal rating 1.0 amps.
3. Terminal D output contact rating 1.0 amps.
4. 5000-02/10 scanner cable available in custom lengths. Replace 5000-02/10 model number with 5000-02/xx. XX is in feet.

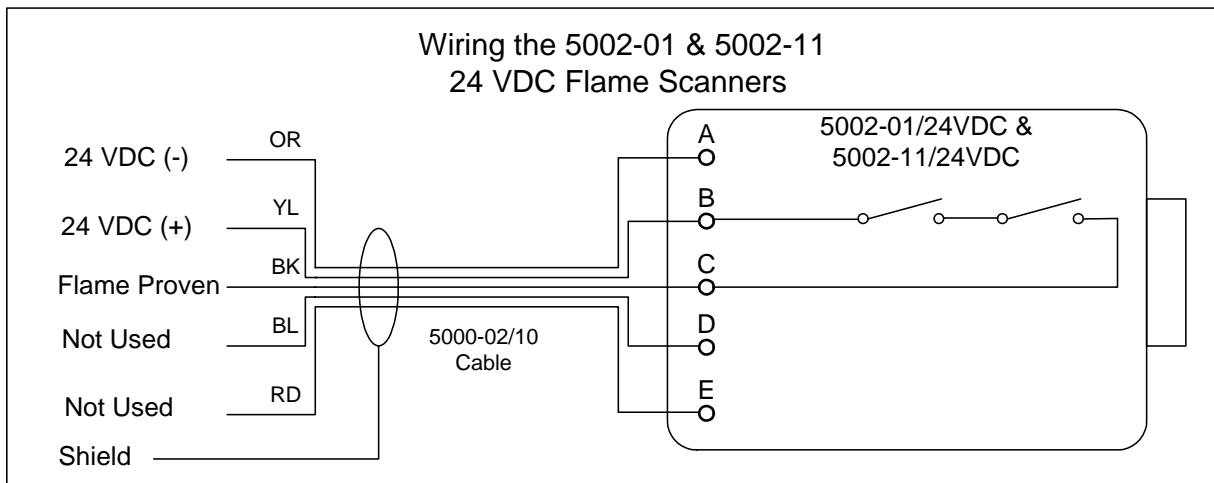



GN ELECTRONICS

A division of Preferred Instruments

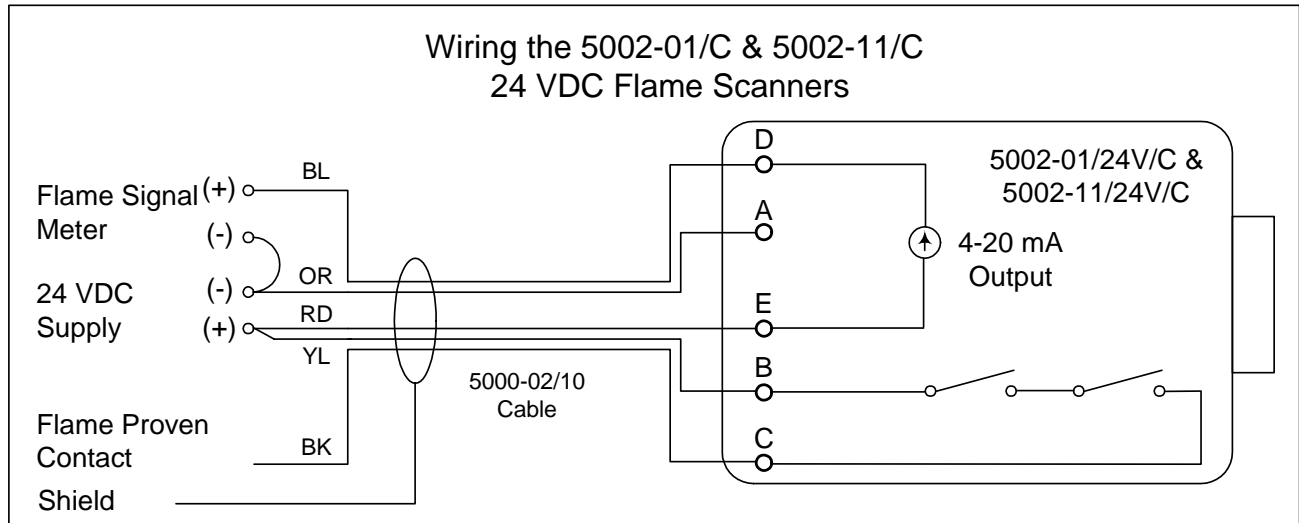

Notes:

1. Wiring shown for 24 VDC power supply.
2. Terminal C relay output terminal rating 1.0 amps.
3. Terminal D output contact rating 1.0 amps.
4. 5000-02/10 scanner cable available in custom lengths. Replace 5000-02/10 model number with 5000-02/xx. XX is in feet.
5. Conductor on pin D may be brown or blue depending on model.

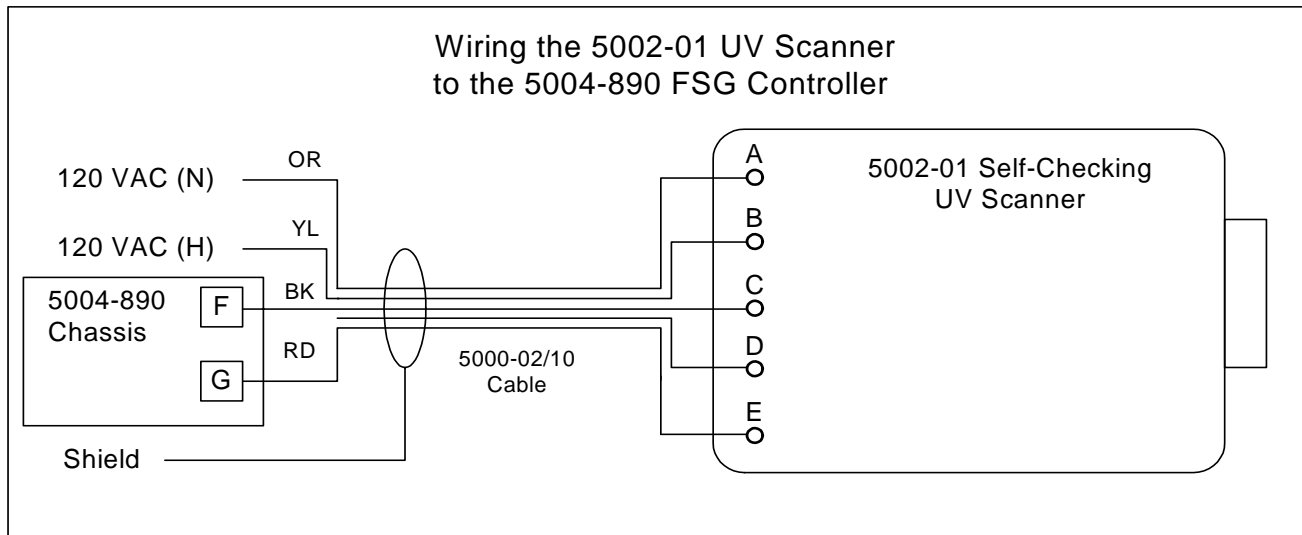

Notes:

1. 120 VAC power to the flame scanner must be from the same source used for the FSG controller (in the same phase)



GN ELECTRONICS

A division of Preferred Instruments

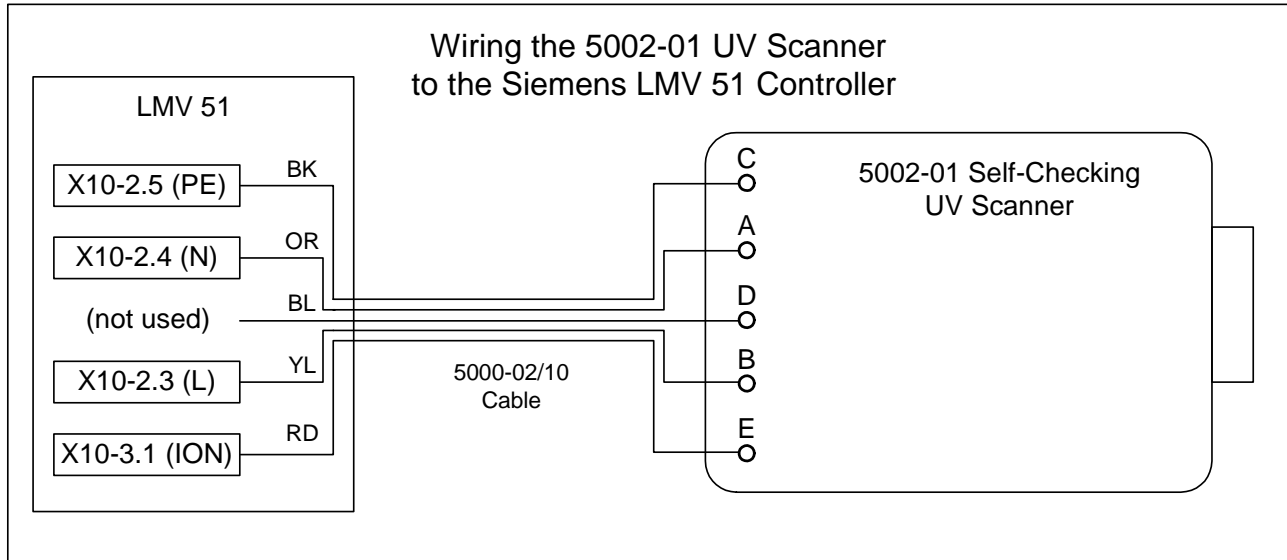



GN ELECTRONICS

A division of Preferred Instruments

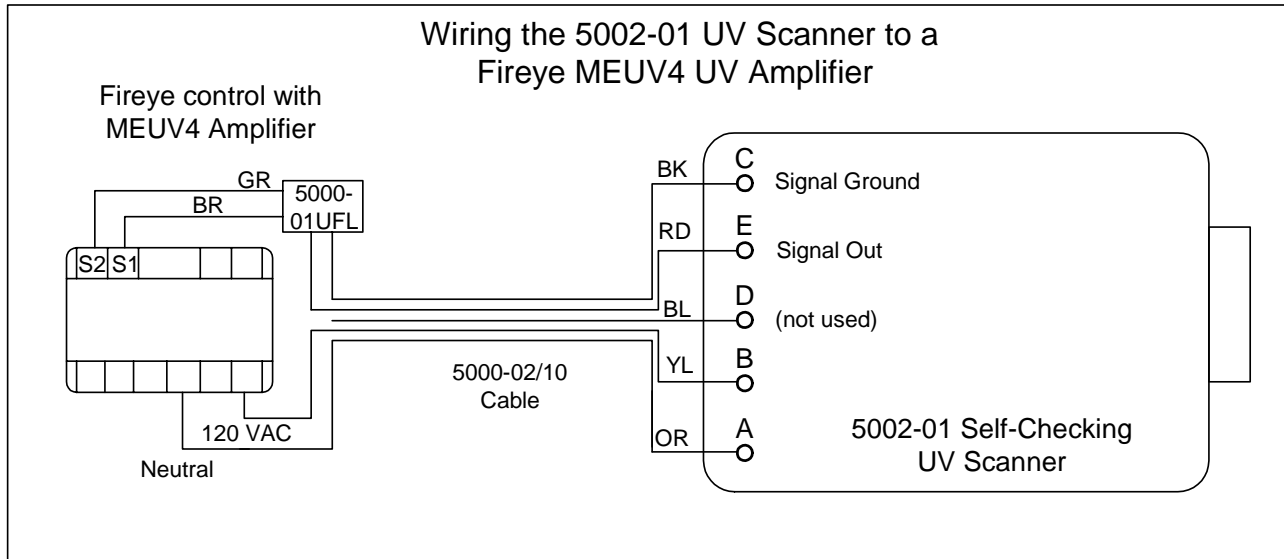

Notes:

1. The 5000-01UFL scanner line filter must be used in this application.

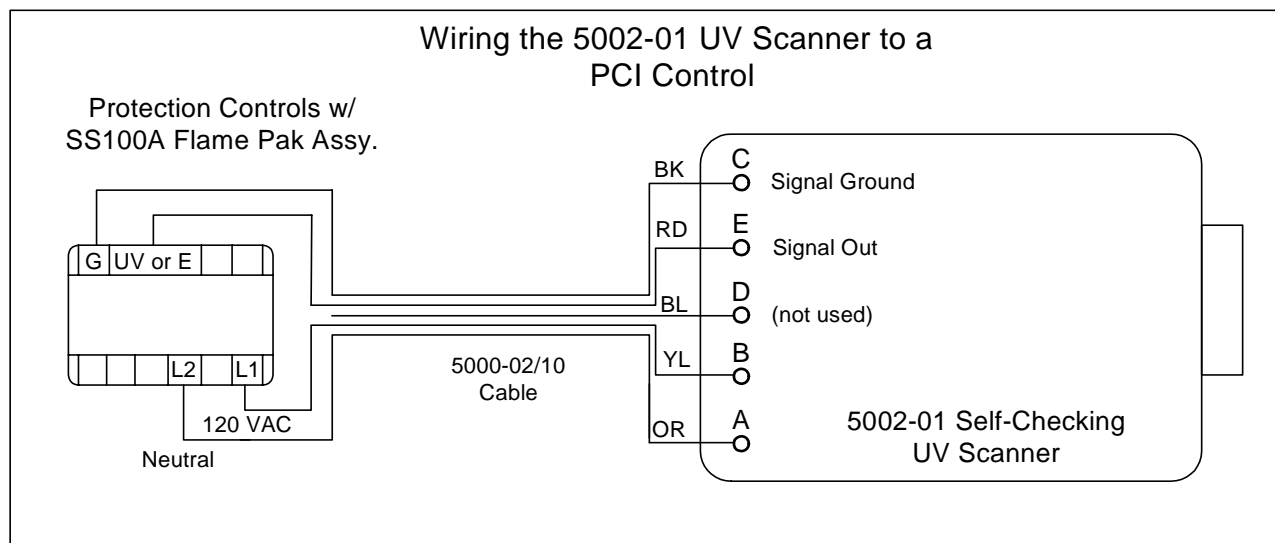



GN ELECTRONICS

A division of Preferred Instruments



Wiring Considerations

Depending on the output option used the wiring requirements will vary somewhat.

Output type	Suggested wire	Wiring run considerations
Contact	14 to 16 AWG	THHN or equivalent Nothing special- can be run with other wires in conduit
4 to 20 ma Flame Signal 1 to 5 volts 0 to 10 volts RS 232 RS 485	14 to 16 AWG	THHN if wire is run in separate conduit
		Shielded cable if multiple wires are in one conduit
		Coax cable if long distance runs are required or if high level of electrical noise is present

Notes:

All wiring runs to the field on, or near, hot surfaces should be rated for 90°C (195°F) or at least 25°C (50°F) higher than the surface temperature.



GN ELECTRONICS

A division of Preferred Instruments



WARRANTY:

This product (5002 Series) is warranted for one (1) year from the date of delivery against manufacturing defects only. GN Electronics standards terms and conditions apply.

GN Electronics' liability for its products, whether due to breach of warranty, negligence, strict liability, or otherwise, is limited to the furnishing of replacement parts and GN Electronics will not be liable for any other injury, loss, damage or expenses, whether direct or consequential, including but not limited to loss of use, income of, or damage to material arising in connection with the sale, installation, use of, inability to use or the repair or replacement of GN Electronics' products.

Units should be returned to G N Electronics. Controls should be well packed in a suitable container encased in appropriate stuffing.

All scanners should **be shipped prepaid to:**

**G N Electronics Inc.
A Division of Preferred Instruments
31-35 South Street
Danbury, CT 06810**