

AUTOMATIC FUEL OIL TRANSFER PUMP SET

The **Automatic Fuel Oil Transfer Pump Set** is a state-of-the-art duplex pump sequencing and monitoring system. This system includes automatic lag pump backup features that improve fuel system availability and safety. A pump set mounted LCD display is used to monitor day tank and pump set status and alarms.

- **Loop or Day Tank Fuel Oil Transfer System**
 - No. 2 or No. 4 Fuel Oil
 - Flows from 20 to 2200 GPH
 - Industrial type Cast Iron Internal Gear Pumps
- **Microprocessor-Based Monitoring And Control**
 - Large LCD display
 - Elapsed Time Recorders
 - Main Storage Tank Gauge and Discriminating Leak Monitoring (optional)
- **Automatic Lead/Lag**
 - Lead pump manual selection or automatic alternation on call for operation or run time hours
 - Automatic lag pump back-up based on lead pump thermal overload, failure to produce flow, fuel demand exceeds capacity of the lead pump
 - Automatic pump prime and suction line integrity check. Fuel transfer system suction piping, pump prime and pump operation are automatically verified each week (adjustable). Fuel system trouble can be identified and repaired before the unit is needed.
- **Alarm and Event Summaries**
 - Alarm and event summary with Time and Date Stamp

The **Automatic Fuel Oil Transfer Pump Set** is a factory packaged, pre-engineered, pre-wired and pre-plumbed system that includes pumps, industrial motors and accessories. These systems are shipped to the job site, requiring only external fluid and electrical connections ensuring undivided responsibility of delivering fuel at the selected flow.

Standard Equipment

- Microprocessor-based control with 16 line x 40 character LCD display and alarm/event and operator action log in a NEMA 4 enclosure.
- Control circuit transformer (if required)
- Alarm bell with alarm silence/reset pushbutton
- Two "Hand-Off-Auto" switches
- "Pump On" indicators
- Two magnetic motor starters with overload protection
- Two motor circuit breakers
- Two pump & motor assemblies
- Two relief valves, two check valves and four ball valves
- Two Simplex inlet strainers
- Inlet compound gauge
- Pump discharge pressure gauges
- Three gauge isolation valves
- Pump Set Flow Proving Switch and Base assembly



Duplex Pump Set with Inlet Oil Strainer and Pump Control Cabinet

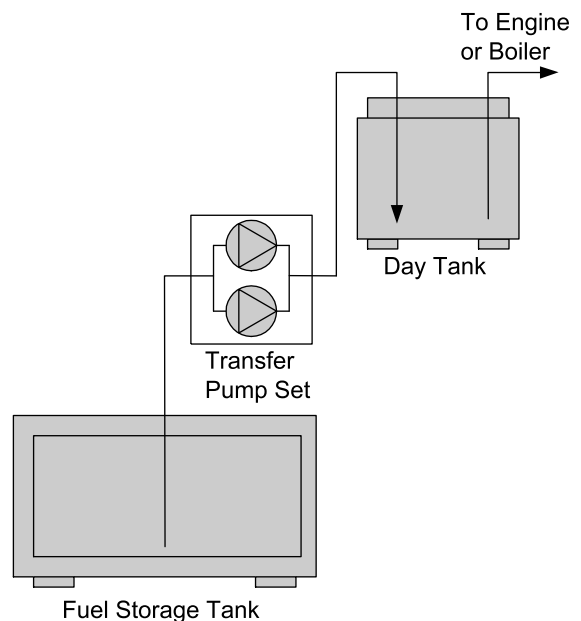

Automatic Pump Set Application Example

AUTOMATIC FUEL OIL TRANSFER PUMP SET

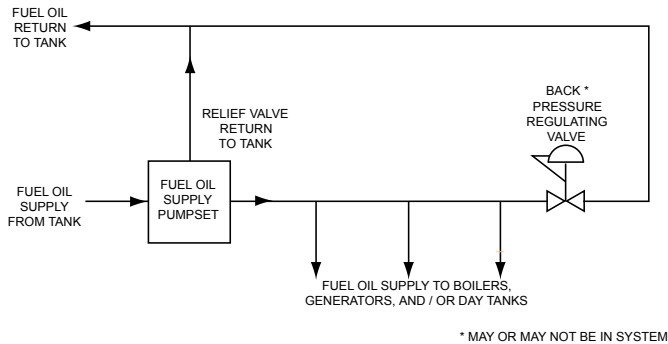

Loop Fuel Oil Transfer System

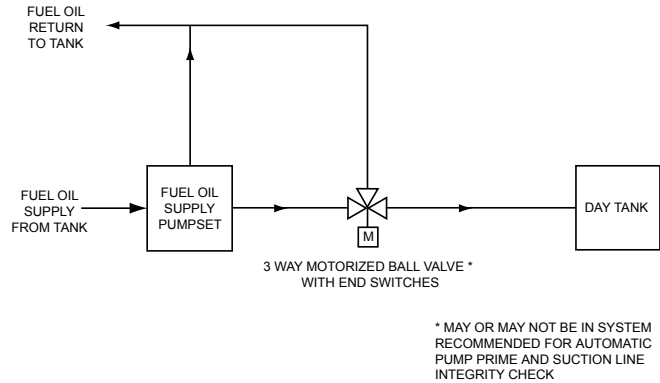

Day Tank Fuel Oil Transfer System

Day Tank Fuel Oil Transfer System

The lead fuel pump is energized when day tank oil level falls below 50%. The lead pump continues to operate until the day tank level is greater than 80%. Upon the next call for fuel, the lead pump automatically alternates. The control system automatically energizes the back-up pump upon detecting a low level condition, (40% full condition). Both pumps then continue to operate until the level of oil reaches the high level point, 90% full condition. Upon detection of loss of flow or pressure or lead pump thermal overload the control system automatically energizes the backup pump and de-energizes the lead pump.

Loop Fuel Oil Transfer System

The lead fuel pump is energized upon a call for oil and run continuously until the demand is removed. Upon the next call for fuel, the lead pump automatically alternates. The lead pump shall automatically rotate every 1 to 168 hours or shall be manually selected by the operator. Upon detection of loss of flow or pressure, or lead pump thermal overload the control system shall automatically energize the backup pump and de-energize the lead pump.

Automatic Pump Prime And Suction Line Integrity Check

Fuel transfer system suction piping, pump prime and pump operation are automatically verified each week (adjustable). The lead pump is automatically energized. Once the lead pump has been proven, the lag pump is energized and run through the same test. These tests are recorded in the controller memory with a time-date stamp for later verification. If either lead or lag pump fails any of these test, the control system generates an audible and visual alarm and logs the "Failed Pump" condition. To permit pump set testing, fuel oil piping system design must allow pump set discharge to return to the main storage tank. The above diagrams show suitable Loop and Day Tank system arrangements. Additionally system designs may include return flow pumps or solenoid valves. Consult Factory for additional information.

Modbus Communication Interface

An easy to setup RS485 Modbus interface is available for off-site monitoring and control.

Alarms / Event Summary

Up to 200 alarms, system events and operator actions are listed in "first in-first out" order with time/date stamp. Alarms include "Pump Thermal Overload", "Pump Loss Of Flow" and "Pump Set Failure" with "Day Tank Leak", "Day Tank High level" and "Day Tank Low level" added for Day Tank Systems. The following events are recorded with time/date stamp: "Pump Started", "Pump Control Switch in "Off" position", "Pump Set Prime Test OK" and "Pump Selected as Lead."

Building Automation System

Building Automation System (BAS) interface includes eight (8) isolated relay contact outputs for "Pump 1 Fail", "Pump 2 Fail", "Strainer High Differential", "Pump Set Leak", "Day Tank High", "Day Tank Low" and "Day Tank Leak" (all when applicable).

Duplex Strainer (Option "-D")

A Preferred **Model 72** duplex fuel oil strainer is provided on the suction side of the pump set instead of the two simplex strainers. Strainer baskets are 40 mesh stainless steel.

Duplex Strainer Differential Pressure Switch (Option "-DP")

A differential pressure switch/indicator with isolation cocks is provided to energize an audible and visual alarm should an excessively dirty strainer condition be detected (Option "-DP" can only be used with option "-D").

Pump Set Leak Detector Switch (Option "-L")

A float-operated Containment Basin Leak detection Switch is provided to shut off the pumps and energize an audible and visual alarm should a pump set leak be detected.

Main Storage Tank Monitoring (Optional)

Up to two (2) tanks, **Model TG-EL-D5-2** may be integrated into the **Model ATPS Transfer Pump Set**

Telephone Modem (Option p/n 190603)

The Modem allows the controller to dial out to an alphanumeric pager in response to alarms or events and allows a technician to dial in to the controller to view all displays and make tuning adjustments.

AUTOMATIC FUEL OIL TRANSFER PUMP SET

Specifications

- Motor Power: 120, 208, or 230 VAC 1 phase or
208, 230, or 460 VAC 3 phase
- Control Circuit Power: 120 VAC 1 phase step down transformer included when selected motor voltage is other than 120 VAC
- Fluid: No. 2 or No. 4 Fuel Oil is standard. Consult factory for other fuel types.
- Pump: Bi-rotational, positive displacement type with cast iron housings and self-adjusting mechanical seals
- Motors: Base mounted, TEFC construction
- Strainer: Simplex, 1/2", 1", 1 1/2", or 2" (according to inlet line size) complete with 40 mesh basket

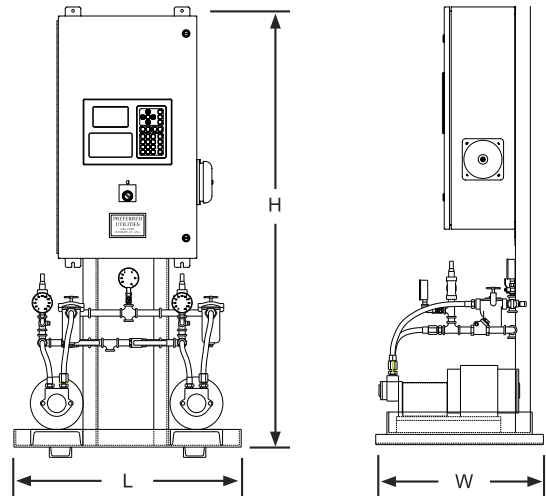

Catalog Size	G.P.H. Oil #2 / #4	P.S.I.	Motor				Dimension			Connection Size		
			R.P.M.	H.P.	Voltage	Phase	L.	W.	H.	Inlet	Outlet	Relief Valve
101	20 / 23	100	1725	1/3	120, 208 or 230	1	30 1/2"	22 1/2"	67"	1/2"	1/2"	1/2"
	23 / 23	50	1725	1/3	120, 208 or 230	1	30 1/2"	22 1/2"	67"	1/2"	1/2"	1/2"
102	27 / 33	100	1725	1/3	120, 208 or 230	1	30 1/2"	22 1/2"	67"	1/2"	1/2"	1/2"
	32 / 33	50	1725	1/3	120, 208 or 230	1	30 1/2"	22 1/2"	67"	1/2"	1/2"	1/2"
103	80 / 93	100	1725	1/3	120, 208 or 230	1	30 1/2"	22 1/2"	67"	1/2"	1/2"	1/2"
	86 / 95	50	1725	1/3	120, 208 or 230	1	30 1/2"	22 1/2"	67"	1/2"	1/2"	1/2"
104	145 / 155	100	1725	1/2	208, 230 or 460	3	30 1/2"	22 1/2"	67"	1/2"	1/2"	1/2"
	155 / 164	50	1725	1/2	208, 230 or 460	3	30 1/2"	22 1/2"	67"	1/2"	1/2"	1/2"
105	282 / 285	50	1725	3/4	208, 230 or 460	3	30 1/2"	22 1/2"	67"	1/2"	1/2"	1/2"
106	277 / 285	100	1725	1	208, 230 or 460	3	30 1/2"	22 1/2"	67"	1/2"	1/2"	1/2"
201	340 / 415	50	1140	1/2	208, 230 or 460	3	65 1/2"	30 1/2"	74"	1"	1"	1/2"
202	300 / 410	100	1140	3/4	208, 230 or 460	3	65 1/2"	30 1/2"	74"	1"	1"	1/2"
203	780 / 890	50	1140	3/4	208, 230 or 460	3	65 1/2"	30 1/2"	74"	1 1/2"	1 1/2"	3/4"
204	700 / 870	100	1140	1 1/2	208, 230 or 460	3	65 1/2"	30 1/2"	74"	1 1/2"	1 1/2"	3/4"
205	1100 / 1300	50	1140	1 1/2	208, 230 or 460	3	65 1/2"	30 1/2"	74"	1 1/2"	1 1/2"	1 1/4"
206	1000 / 1200	100	1140	2	208, 230 or 460	3	65 1/2"	30 1/2"	74"	1 1/2"	1 1/2"	1"

Pump set ratings are nominal at pressures shown with a maximum 10" Hg vacuum at pump inlet

Ordering Information

1. Specify the pump set catalog number as follows:

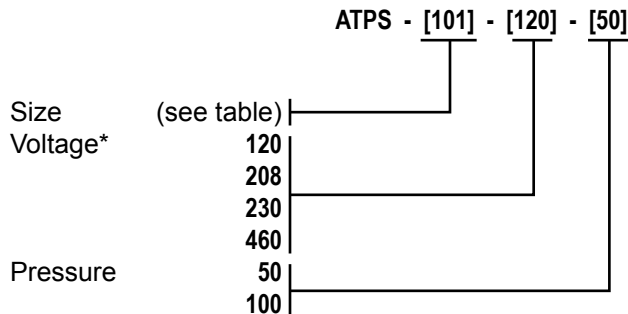

* Pump Set sizes 101 through 103 are single phase only, sizes 104 through 206 are three phase only.

- Specify Loop or Day Tank application.
- Consult Factory for custom sizes.

Optional Features	Catalog Number
Duplex Strainer in lieu of two simplex strainers	add "-D" suffix
Duplex Strainer Differential Pressure Switch	add "-DP" suffix
Pump Set Leak Detection Switch	add "-L" suffix
Building Automation System (BAS) Discrete Output Contacts	add "-BAS" suffix
Telephone Modem	190604

- Specify Tank Gauge **Model TG-EL-D5**. Up to two (2) tanks, a **Model TG-EL-D5-2** may be integrated into the **Model ATPS Transfer Pump Set**.
- Specify any other application or monitoring requirements.

AUTOMATIC FUEL OIL TRANSFER PUMP SET

Suggested Specifications

1. Application

Supply a self-contained, Automatic Fuel Oil Transfer and Monitoring System to ensure a reliable supply of fuel oil to the emergency generators or boilers included in this project. The system shall include automatic pump set lead/lag, storage tank and day tank level monitoring, leak monitoring, LCD operator display, manual back-up stations, time and date stamped alarm and event summary, and the system shall include the capability to simultaneously communicate to a Data Acquisition System (DAS), Building Automation System (BAS) or Building Management System (BMS) via Modbus protocol, and dial out to an alphanumeric pager system via field installable plug-in option modules in the future. The control system shall be a microprocessor-based design with field expandable plug-in Input/Output modules. The Automatic Fuel Oil Transfer Pump and Straining Set and monitoring system shall be Preferred Utilities Mfg. Corp. Danbury, CT **Model ATPS-LO-___** rated at ___GPH of (No. 2), (No. 4), (Diesel) oil against a discharge pressure of ___PSig.

2. Pump Set and Control Cabinet

The Pump Set and Control Cabinet shall be completely pre-wired and tested to ensure job site reliability. The pump set and control cabinet shall be the product of one manufacturer for single source responsibility. Provide a factory assembled NEMA 4 steel enclosure with all operator interface control switches, indicators and displays physically separated from any field terminations.

3. Control and Monitoring Hardware

The control strategy shall be microprocessor-based. RELAY LOGIC SHALL NOT BE ACCEPTABLE. The control strategy shall be factory configured and stored on a EEPROM, and shall be password protected from re-configuration by unauthorized/un-qualified personnel. The controller shall be designed so that it will "fail safe" in the event there is a microprocessor failure. Control hardware shall include combination magnetic motor starters with overload protection and circuit breakers. Provide safety interlocks to shutdown both pumps during any of the following conditions: day tank "leak detected" and "high" day tank level. These interlocks must continue to ensure safe pump operation even if the controller has failed or is out of service and the pump set is operated in manual "hand" mode.

4. Operator Interface

The control system shall include a 16 line x 40 character or greater LCD display for pump set status, storage tank level indication, alarm listing, and trouble shooting functions. Provide a tactile feedback, numeric keypad for data entry. Provide dedicated pushbuttons for Alarm Silence and for the Home Page display and a "Hand-Off-Automatic" control switch for each fuel pump. In "Hand" position the pump shall be capable of manual operation in the event of a controller failure. The control system shall monitor the position of each "Hand-Off-Automatic" control switch. Should a switch be put into the "Off" position, the controller shall log the event with a Time/Date stamp and store within the controller memory. Provide an Elapsed Time Recorder (ETR) to measure running time for each pump. Provide a Fuel Oil Overview Display (Home Page) capable of simultaneous viewing of pump set status, day tank status and main storage tank status. The Fuel Oil Overview display shall include the following information:

- a) Lead Pump Selection – Auto/Manual
- b) Pump Status – Off/Run/Standby
- c) Day Tank Status – Normal/High/Low/Leak
- d) Main Tank Status – Normal/High/Low/Leak
- e) Three Most Recent Alarms

5. Alarm and event Logs

The control system shall include a 200 Alarms, events and operator actions memory minimum. Provide an alarm display page for viewing the most recent 8 alarms/events with scrolling capability to view the complete 200 point alarm/event memory. Each event and alarm condition must be displayed with a distinct, descriptive, English language description and time and date stamp. New alarms shall trigger the common alarm output relay. Events shall be recorded, but shall not trigger an alarm. A dedicated Alarm Silence button shall silence the alarm output. The control system shall record and annunciate the following alarms: Pump Thermal Overload, Pump Loss Of Flow, Pump Set Failure, Day Tank Leak, Day Tank High level and Day Tank Low level. The control system shall record the following events: Pump Started, Pump Control Switch in "Off" position, Pump Set Prime Test OK, and Pump Selected as Lead.

6. Fuel Pump Alternation and Lead-Lag Operation [Day Tank Fuel Oil Supply Applications]

Provide automatic, microprocessor-based day tank level control. The lead fuel pump shall be energized when Day Tank oil level falls below 50%. The lead pump shall continue to operate until the day tank level is greater than 80%. Upon the next call for fuel, the lead pump shall be automatically alternated. The control system shall automatically energize the back-up pump upon detecting a low level condition (40% full condition). Both pumps shall then continue to operate until the level of oil reaches the high level point (90% full condition). Upon detection of loss of flow or lead pump thermal overload the control system shall automatically energize the backup pump and de-energize the lead pump.

7. Fuel Pump Alternation and Lead-Lag Operation [Loop Fuel Oil Supply Applications]

Provide automatic, microprocessor-based fuel oil transfer pump control based upon a call for oil. The lead fuel pump shall be energized upon a call for oil from the boiler and run continuously until the demand is removed. Upon the next call for fuel, the lead pump shall be automatically alternated. The lead pump shall automatically rotate every 1 to 168 hours or shall be manually selected by the operator. Upon detection of loss of flow or pressure or lead pump thermal overload the control system shall automatically energize the backup pump and de-energize the lead pump.

8. Automatic Pump Prime and Suction Line Integrity Check

The control system shall include a battery-backed, real-time clock and must be capable of automatically energizing the lead pump once every day. This is to verify suction piping integrity and pump prime and verify pump operation. Once the lead pump has proven satisfactory operation, the lag pump shall be energized and run through the same test. These tests shall be recorded in the controller memory with a Time/Date stamp for later verification. If either lead or lag pump fails any of these tests, the control system shall generate an audible and visual alarm and log the "Failed Pump" condition.

AUTOMATIC FUEL OIL TRANSFER PUMP SET

Suggested Specifications

9. Main Storage Tank Monitoring

The control system shall include main storage tank level sensor and discriminating leak sensor monitoring. Provide a continuous display of tank content, in both gallons and inches of product, within the main storage tank. Tank alarm displays shall not interfere with the display of the tank content. Provide data recall of the instantaneous display of tank content at the time of leak alarm condition. The control system shall include an overfill alarm circuit test pushbutton to provide instantaneous proving of audible and visual alarm circuitry associated with instrument overfill alarm contact. The controller must be field expandable using plug-in input modules to monitor up to 4 storage tanks and 12 discriminating leak sensors. Provide all equipment capabilities specified in this paragraph even if a connecting level and leak sensors are not included in this project.

10. Piping And Mounting

Provide a duplex pump and straining set that is factory assembled with components piped and mounted on a continuously welded steel plate containment basin with 3" steel side rails. Provide a ½" containment basin plugged drain connection. The basin shall be sized to contain (capture) potential leaks from all factory installed piping and components. Pipe shall be schedule 40 ASTM A-53 Grade "A" with ANSI B16.3 Class 150 malleable iron threaded fittings.

11. Positive Displacement Pumps

Provide and mount two (2) positive displacement rotary type pumps, with cast iron housing and self-adjusting mechanical, Carbon ring seals. Pumps that have aluminum, brass, or bronze housings or rotors are not acceptable. Packing gland equipped pumps, close-coupled pumps, Carbonator shaft mounted pumps or centrifugal pumps are not acceptable.

12. Motors

Provide and mount two (2) TEFC, rigid base, standard NEMA frame motors. Pump and motor assemblies shall be factory assembled on a structural steel channel. Rotating parts shall have a steel OSHA guard.

13. Pump Isolation and Check Valves

Provide and mount four (4) pump isolation valves. Locate one (1) valve on the suction and discharge side of each pump. Isolation valves will allow off-line pump maintenance without system loss of availability. Isolation valves shall be ball type valves to provide full flow while open and positive shutoff when closed. Additionally, two (2) check valves shall be provided and mounted, one (1) located on the discharge of each pump.

14. Fuel Oil Strainer

Provide and mount two (2) simplex strainers with 40 mesh baskets, one (1) located on the suction side of each pump.

15. Relief Valves

Provide and mount two (2) relief valves sized to relieve the full outlet flow of the pump without causing the pump motor to overload or any component's pressure rating to be exceeded if the discharge is inadvertently valved off. Relief valves must be externally mounted from the pumps and piped to the return line in the field according to NFPA 30. Pump internal relief valves shall not be accepted. Relief valves shall be Preferred **Model R**.

16. Compound And Pressure Gauges

Provide and mount a compound gauge on the suction side of the strainer. The gauge shall read 30" vacuum - 15 PSIG. Provide and mount a pressure gauge on the discharge side of each pump. Each gauge shall be equipped with an isolation ball valve.

17. Pump Automatic Sequencing Flow Switch

Provide a time delayed flow sensing switch on the discharge of the pump set to bring on the lag pump should the lead pump fail to maintain flow. Flow switch shall be vane operated to actuate a single double throw snap switch. Switch shall be factory wired to the control cabinet for alarm and backup pump operation. Switch shall be rated for 250 PSIG. Provide a flow switch outlet isolation valve for maintaining the flow switch without draining the fuel system.

18. Communications

The pump set must include an optically isolated RS485 communications data highway. The RS485 protocol shall allow: Auto/Manual mode change, lead pump selection, sensing and silencing of alarms, change of any configuration parameter, change of timers, etc. Provide all equipment capabilities specified in this paragraph, even if a connecting BAS system is not included in this project. It must be possible to field upgrade the control system to "dial out" to an alphanumeric pager system via field installable plug-in option modules in the future.

19. Quality Assurance

The Control Cabinet shall be manufactured and labeled in accordance with UL508A (CSA C22.2 #14 for use in Canada). Simply supplying UL recognized individual components is not sufficient. The assembled control cabinet, as a whole, must be inspected for proper wiring methods, fusing, etc., and must be labeled as conforming to UL508A. Inspection and labeling shall be supervised by UL or other OSHA approved Nationally Recognized Test Lab (NRTL). The system must be manufactured by a nationally recognized Trade Union (I.B.E.W. or similar trade union). Lack of an NRTL certified UL508A wiring methods inspection and label or lack of a Trade Union label will be grounds for rejection.

20. Factory Testing

Pump Sets must be fully tested prior to shipment. Testing shall include both a pressure and vacuum testing period. First, the complete pump set shall be pressure tested to rated pressure using an air pressure source. The test shall confirm that the pump set piping system can maintain rated pressure for 4 hours. Next, the complete pump set shall be brought to a vacuum greater than 25" Hg. The test shall confirm that the pump set piping system can maintain vacuum for 4 hours. Following a pressure and vacuum test the pump set shall be given a full operational test. The pump set shall be connected to a fuel oil supply and return. The pump set shall be operated normally. Motor amps shall be noted at no load and full load for each motor. The motor amps shall be within 10% of rated motor amps. During the test the relief valve shall be set and tested. Operation of pump set instrumentation shall be tested. A copy of the test procedures shall be sent to the consulting engineer and owner. The owners and or the consulting engineer, at their discretion, shall observe this and all other tests. A certificate of factory testing, together with a copy of the wiring and arrangement diagrams shall be placed in the control cabinet prior to shipment.