

# Preferred Instruments

31-35 South Street, Danbury CT 06810  
203-743-6741 www.preferredinstruments.com

## JC-15D Flue Gas Temperature Monitor Installation & Operation Instructions

### Description

The **JC-15D** Flue Gas Temperature Monitor is a microprocessor-based indicating instrument with a heavy duty thermocouple assembly. Flue gas temperature is continuously displayed using a highly visible backlit LCD display. An intuitive bargraph display and alarm messages provide clear stack temperature status. Bargraph Scaling, Alarm Setpoints, and Time Delays are all field selectable. All adjustments can be made directly from the faceplate of the instruments by scrolling through user friendly, English-language menus.

The type J Thermocouple Assembly is constructed of a seal welded inconel sheath for corrosion protection, and can be directly installed in the boiler's flue gas outlet. The unit includes a ½" male NPT process connection, cast iron head with terminal block, and ½" female NPT electrical connection.

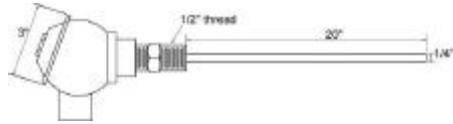

### Alarm Sequence

Bargraph and Numeric displays continuously indicate the flue gas temperature (FGT). If the FGT exceeds the Warning Setpoint for more than 30 seconds (adjustable), the bargraph blinks, the WARNING message appears, and the Common Alarm Relay energizes. Pressing the ALARM SILENCE button de-energizes the Common Alarm Relay. If the FGT continues to increase and exceeds the Shutdown setpoint for more than 15 seconds (adjustable), the bargraph blinks, the SHUTDOWN message appears, the Shutdown relay de-energizes and latches into "Manual Reset" mode, and the Common Alarm Relay re-energizes. If the **JC-15D** Shutdown relay is wired into the burner interlocks, the burner shuts down. The Shutdown Relay remains de-energized and the SHUTDOWN message remains on the display until the Operator presses the RESET pushbutton.

The Common Alarm Relay can be used to activate an external bell or horn. If the **JC-15D** is not in SHUTDOWN, the Common Alarm Relay de-energizes automatically when the temperature drops below the Warning Alarm setpoint. Alternately, pressing the **JC-15D** Alarm Silence pushbutton, or energizing the 120 Vac Alarm Silence input, or sending a Modbus command can de-energize the Common Alarm Relay in order to silence an audible alarm.

### Table of Contents:

Description .....	1	Menus .....	5
Alarm Sequence .....	1	Menu Structure JC-15D Smoke Opacity Monitor .....	6
Specifications .....	2	Setup .....	6
Operation .....	2	LCD Display Contrast .....	6
Installation .....	3	Input Type, Display Units, Bargraph Setup .....	6
JC-15D Indicator Mounting: .....	3	Alarm Setpoints, and Time Delays .....	7
Temperature Sensor Mounting: .....	3	4-20 mA Temperature Output Scaling .....	7
Wiring: .....	4	Smoothing Filter and Calibration Offset .....	7
		Troubleshooting .....	8
		Modbus Communications .....	8

## Specifications

### Panel

Power Supply: 120Vac, +/- 15%, 50/60Hz, 15 VA  
 Case Size: 8"H x 3.5"W x 7.5"D  
 Enclosure Type: NEMA 12 faceplate, Indoor locations  
 Ambient Temp.: +32° to 122° F  
 Displays: High contrast LCD display  
 4" high Bargraph, 0.5% resolution  
 Bargraph Range: 0-2000 deg  
 (field adjustable top and bottom values)  
 Alarm Setpoints: Warning Alarm with adj. time delay  
 Shutdown Alarm with adj. time delay  
 Shutdown Alarm requires manual reset

### Inputs

Sensor: Type J or Type K thermocouple  
 (field selectable)  
 Accuracy: 0.2 deg F resolution  
 0.1% linearity  
 Break Protection: Upscale  
 Remote Silence: 120 Vac / 10 mA, Optically Isolated

### Outputs

Temperature: 4-20 mA, 650 ohm load  
 (field adjustable scaling)  
 Relay Outputs: 10 A Resistive, 8 FLA, ½ Hp, 120 Vac  
 Communications: Modbus, ASCII or RTU  
 RS485, 1200 - 38400 Baud

### 104087D Thermocouple

Sensor: Type J, un-grounded, 0-1000 F  
 Probe Sheath: Inconel  
 Insertion Length: 20"  
 Connection: ½" MNPT  
 Head: Cast Iron, screw terminal block

### Ordering Information:

Part Number	Description
JC-15D	Flue Gas Temperature Monitor
104087D	20" Type J Thermocouple, ½" MNPT process connection (no extension wire)
101668C16	Unshielded Type J thermocouple extension wire
92088-J-B20PP	Shielded Type J thermocouple extension wire
SDA-B6	Alarm Bell, 6" dia, 85 db, 120 Vac
21009	¼ amp Slo-Blo, 250 V,3AG fuse
90265	Replacement LCD display
90248	Replacement Mylar Keyboard Overlay
90256	Panel Mounting Gasket

## Operation

Flue Gas Temperature (FGT) is continuously displayed at the top of the indicator. The Bargraph height varies in proportion to the FGT. The Bargraph top and bottom scaling can be adjusted via the **JC-15D** Menu to any range between 0-2000 degrees.

The **JC-15D Common Alarm Relay** is typically wired to an external audible alarm (bell, horn, strobe,...). Press the **Alarm Silence** button to silence any external audible alarms that are connected to the **JC-15D**.

The **JC-15D Shutdown Relay** contacts are typically used to shutdown the burner if the FGT has been above the Shutdown Setpoint for more than 15 seconds (adjustable). Press the **RESET** button (after the FGT drops below the Shutdown Setpoint) to allow the burner to re-start and to clear the SHUTDOWN message from the display .

The Bargraph blinks while **WARNING** or **SHUTDOWN** is displayed.

The LCD display contrast is adjustable from the MAIN Menu.

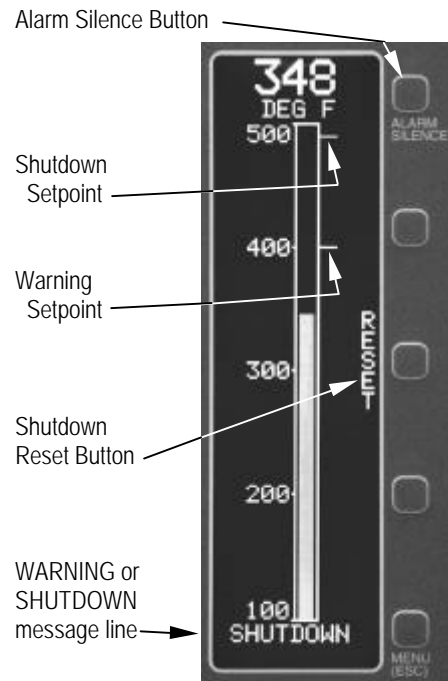

## **Installation**

### **JC-15D Indicator Mounting:**

The JC-15D Indicator is designed for flush mounting in an enclosure located in an indoor NEMA 12 environment. The JC-15D should not be subjected to excessive vibration. Continuous operation is guaranteed within the 32-122 F (0-50C) ambient operating range.

- Cut a rectangular hole and drill two 5/32" mounting holes in the panel.
- If NEMA 12 water mist protection is required, apply the supplied gasket onto the panel.
- Remove the nuts from the JC-15D mounting studs.  
NOTE: Hold the JC-15D faceplate in place after the nuts are removed.
- Put the JC-15D into the panel hole and re-install the nuts on the mounting studs from the inside of the panel.

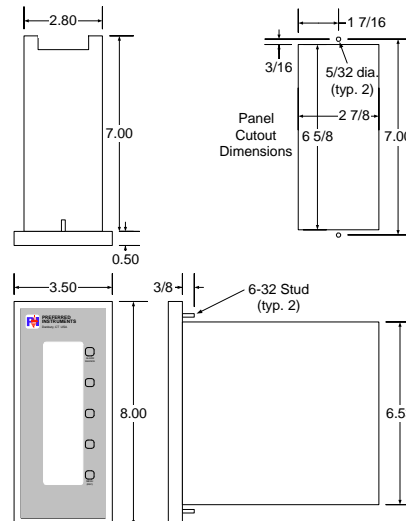

### **Temperature Sensor Mounting:**

The 104087D type J thermocouple temperature sensor is designed for mounting in a NEMA 4 environment. The thermocouple should not be subjected to excessive vibration.

- Locate the temperature sensor where the tip of the probe will sense a representative flue gas temperature. Typically, the tip should be in the middle 1/3 of the flue gas duct.
- Insulate around the duct connection to prevent melting the thermocouple extension wire jacket (220 F max.). If necessary, install an extension nipple and coupling to allow for additional thermal insulation. Do not mount through the top of a duct to prevent melting the extension wiring.
- The wiring connection is 1/2" FNPT.

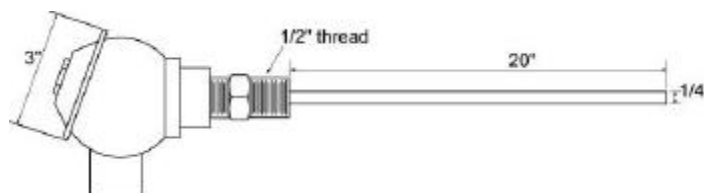

**Wiring:**

**Warning**

Disconnect all sources of power before installing or servicing this equipment. Multiple Disconnects may be required. Burner interface wiring must be performed by an experienced burner service technician.

All wiring must comply with all local and national electrical codes. Tighten all terminals to 4.4 in-lb. Wire must be stranded copper, 12-24 ga., 150V / 60 C insulation minimum. AC and DC wiring must be separated to prevent electrical noise coupling. Do not run AC and DC wires in the same conduits. Use shielded cables where shown, connect shields only where shown, insulate all other shields to prevent accidental grounding. Ignition transformer and motor VFD wiring are particularly noisy and should be kept away from the thermocouple extension wire, and also all other AC and DC wiring.

- The wiring from the thermocouple to the JC-15D must be thermocouple extension wire. Do not use copper wire for any part of this wiring. Use the same wire type as the thermocouple: type J wire for a type J thermocouple.
- The Red wire is the '-' for all thermocouple types. Connect the Red wire to the red or '-' screw in the thermocouple head. Connect the Red wire to JC-15D terminal 12.
- Avoid splicing the thermocouple extension wire. Each splice is a potential source of temperature error.
- If shielded thermocouple wire is used, insulate the shield wire inside the thermocouple head to prevent shorting to ground.
- If the 4-20 mA output will not be used, jumper terminal 16 to 17 to prevent the OUTPUT FAILURE error message.
- Relay contacts are shown with power removed from the JC-15D. In normal operation Relay 2 is energized. Relay 2 de-energizes to shutdown the burner.
- Relay contacts have internal surge suppressors and are rated: 10 A resistive, 8 FLA / ½ Hp / 120 Vac
- All DC wiring is isolated from Ground.
- All DC wiring '-', shield, and 'Common' terminals are connected together internally.
- Terminals 1-9 are Line Voltage AC. Terminals 10-26 are low voltage DC.

**Fuse:** ¼ amp Slo-Blo, 250 V, 3AG (Preferred Instruments 21009, Littlefuse p/n 313 .250)

**Caution:** To reduce the risk of fire, only replace fuse with the same type.

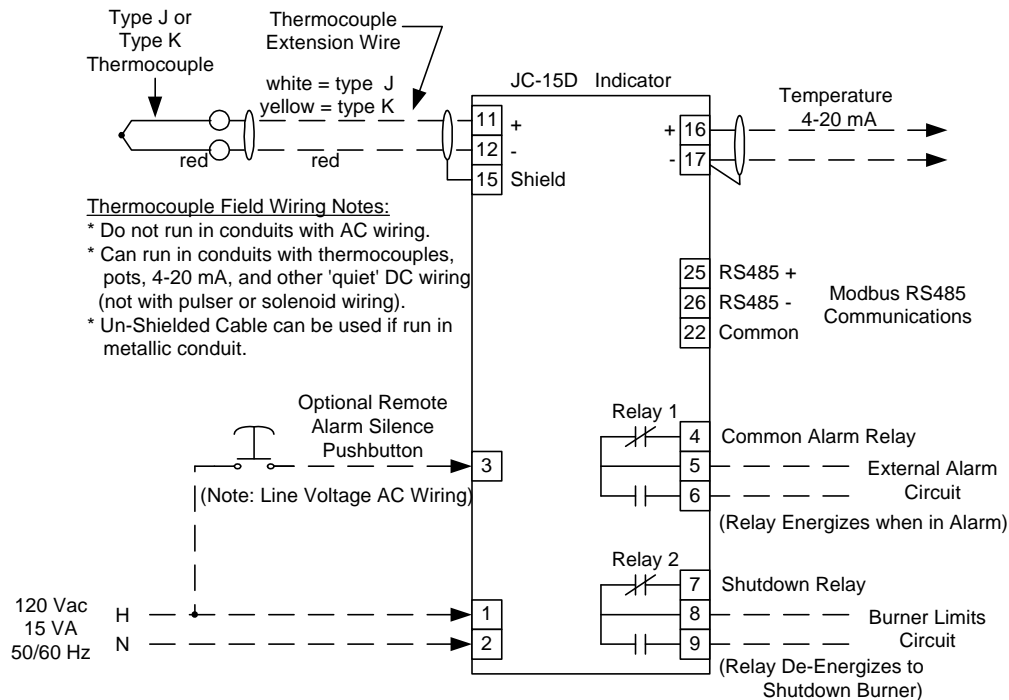

## Menus

Alarm Setpoint and time delay adjustment, Bargraph scaling, LCD contrast adjustment and all other changes are made via the JC-15D Menu. This overview shows how to navigate through the JC-15D Menu and Sub-Menus. The detailed descriptions of each parameter will be discussed in the sections that follow.

From the bargraph display, press the MENU button to activate the MAIN MENU.

When the Menus are being displayed, the MENU button becomes the ESCape button. Pressing ESCape either cancels the current editing operation, or returns to the previous Menu, or exits the Main Menu and returns to the Bargraph display.

The items inside the box in the middle of the screen are the current Menu line item. Items above or below this box are previews of the next Menu lines.

Press UP or DOWN to scroll to the next Menu lines.

Press SELECT to edit the value of the current item or to activate the Sub-Menu.

Press ESC to exit a Menu or to cancel the editing of a value.

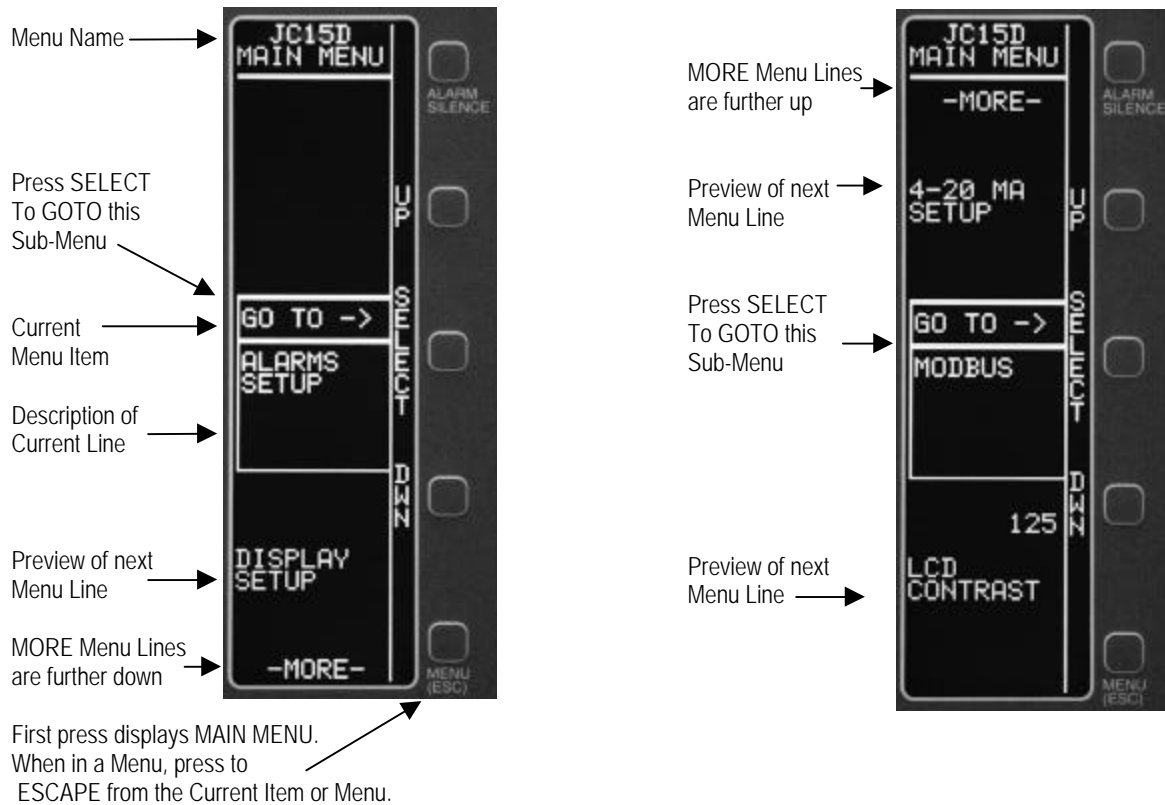

**Menu Structure JC-15D Flue Gas Temperature Monitor**

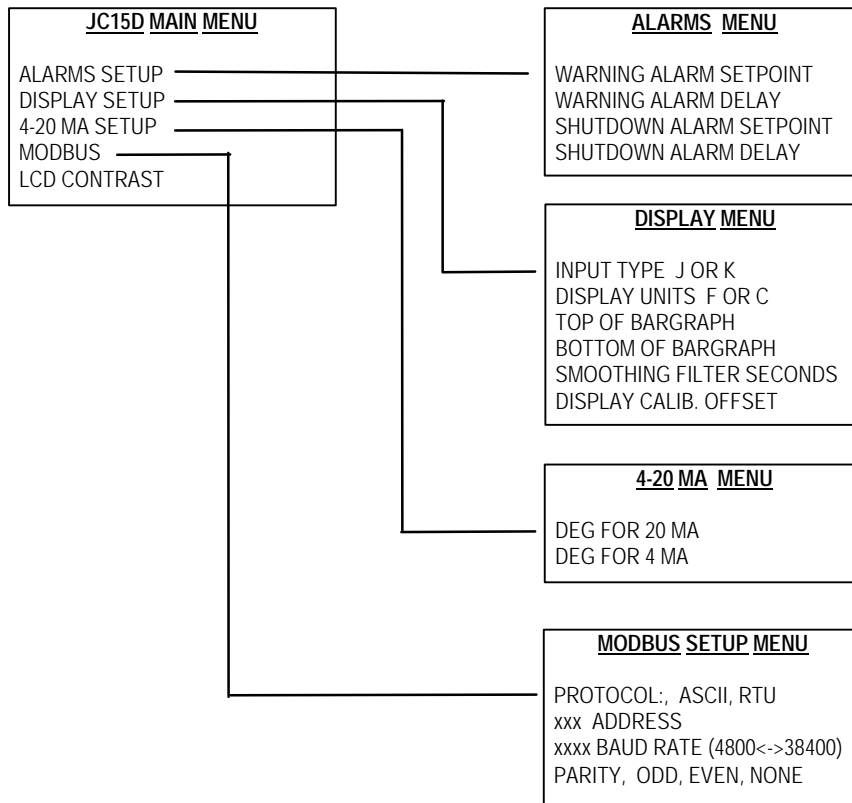

**Setup**

**LCD Display Contrast**

After installing the **JC-15D**, apply 120 Vac power, Select the Main Menu item: **LCD CONTRAST**, and adjust the value until the display contrast suits the installed viewing angle.

**Input Type, Display Units, Bargraph Setup**

Set the INPUT TYPE to match the installed thermocouple type.

Set the DISPLAY UNITS for Fahrenheit or Centigrade, as desired.

Set the TOP and BOTTOM bargraph values to suit the expected operating range of the boiler or furnace.

Actual	Default	Max.	Min.	DISPLAY Menu Items
	J	J	K	<b>INPUT TYPE J OR K</b> Type J thermocouples operate over the 0-1000 F range. Type K thermocouples operate over the 0-2000 F range.
	F	C	F	<b>DISPLAY UNITS F OR C</b> Select the desired temperature units, Fahrenheit or Centigrade.
	500	2000	0	<b>TOP OF BARGRAPH</b> This is the temperature value at the top of the bargraph. The units are F or C, as selected above.
	100	2000	0	<b>BOTTOM OF BARGRAPH</b> This is the temperature value at the bottom of the bargraph. The units are F or C, as selected above. The difference between TOP and BOTTOM should be evenly divisible by 4 for an easy-to-read bargraph display scaling.

Setup (continued)

**Alarm Setpoints, and Time Delays**

Set the WARNING ALARM SETPOINT above the highest normal operating temperature. The intent is to trip this alarm when it is time to clean excessive soot or scale build-up.

Set the SHUTDOWN ALARM SETPOINT to the flue gas temperature that will cause damage to the boiler or furnace (Consult the boiler mfg.). The intent is to shutdown the burner when the flue gas temperature is so high that boiler damage is immanent.

Actual	Default	Max.	Min.	ALARMS Menu Items
	400	2000	100	<b>DEG, WARNING ALARM SETPOINT</b> This Setpoint is used for the Warning Alarm logic.
	30	1200	1	<b>SEC, WARNING ALARM DELAY</b> The Common Alarm relay (Relay 1) energizes when the Temperature has been above the Alarm Setpoint for more than 'Warning Alarm Delay' seconds. Once the Warning Alarm has been triggered, the temperature must drop 5 degrees below the Setpoint before the Warning Alarm de-activates.
	490	2000	200	<b>DEG, SHUTDOWN ALARM SETPOINT</b> This Setpoint is used for the Shutdown Alarm logic.
	15	300	1	<b>SEC, SHUTDOWN ALARM DELAY</b> The Shutdown relay (Relay 2) de-energizes when the Temperature has been above the Shutdown Setpoint for more than 'Shutdown Alarm Delay' seconds. The temperature must drop 5 degrees the Shutdown Setpoint and the Operator must press the RESET button in order to re-energize the Shutdown relay.

**4-20 mA Temperature Output Scaling**

Adjust for the desired 4-20 mA output temperature scaling. The temperature units are F or C as selected above.

Actual	Default	Max.	Min.	4-20 MA Menu Items
	1000	2000	100	<b>DEG FOR 20 MA</b> This is the temperature value for 20 mA output.. The units are F or C, as selected above.
	0	1900	0	<b>DEG FOR 4 MA</b> This is the temperature value for 4 mA output.. The units are F or C, as selected above.

**Smoothing Filter and Calibration Offset**

Actual	Default	Max.	Min.	DISPLAY Menu Items
	2.0	30.0	0.5	<b>SEC, SMOOTHING FILTER</b> Dampens (smoothes) rapid temperature display variations. Larger values = more damping. Smaller values = less damping.
	0	+10	-10	<b>DEG, DISPLAY CALIB. OFFSET</b> The displayed value is offset from the measured value by this amount for all temperatures. Used to calibrate out minor temperature differences due to sensor errors. The units are F or C, as selected above.

## Troubleshooting

The displayed temperature is not what you expected:

- Verify that the Red wire is connected to the Red (-) terminal of the thermocouple and to terminal 12 of the JC-15D.
- Verify that the INPUT TYPE and DISPLAY UNITS are set correctly in the DISPLAY MENU.
- Remove the thermocouple wire from JC-15D terminals 11 & 12. Jumper terminal 11 to terminal 12 with copper wire. The JC-15D should display the ambient temperature near the JC-15D terminal blocks.
- If the ambient temperature is displayed with the jumper installed, then the problem is in the interconnecting wiring or the thermocouple is the wrong type.
- Verify that the wiring from the thermocouple to the JC-15D is the correct type of thermocouple wire ( and not copper wire). The standard color code is red and white for type J, and red and yellow for type K.
- Move the tip of the thermocouple within the duct to determine if the temperature changes.
- Check for loose splices in the field wiring. Check for shields touching ground.

## Modbus Communications

Field Selectable via the MODBUS menu:

Protocol: RTU or ASCII

Address: 1-247

Baud: 1200, 4800, 9600, 19200, 38400

Parity: Odd, Even, None ('No Parity' requires 2 Stop bits)

Register Format: Signed Integers, -32767 to + 32767

Modbus Commands: 01 Read Coils, 03 Read Holding Registers, 05 Write Single Coil, 06 Write Single Holding Register  
(A maximum of 10 coils or registers can be read in a single poll)

Coil		0 =	1 =	Description
150	RW		Silenced	Alarm Silence
151	RO		Energized	Common Alarm Relay
152	RO		Warning	Warning Alarm
153	RO		Shutdown	Shutdown Alarm
Register		JC-15 Value	Modbus Value	
40150	RO	100 deg	100	Temperature
40151	RW	100 deg	100	Alarm Setpoint
40152	RW	100 seconds	100	Alarm Time Delay Seconds
40153	RW	100 deg	100	Shutdown Setpoint
40154	RW	100 seconds	100	Shutdown Delay Seconds
40155	RO	1	1	Thermocouple type: 0 = K, 1 = J
40156	RO	1	1	Temperature Units: 0 = F, 1 = C

## Preferred Instruments

31-35 South Street, Danbury, CT 06810  
203-743-6741 www.preferredinstruments.com