

# DRAFT CONTROLLER

Model JC-22D

Uncontrolled stack draft can cause burner instability, unreliable ignition, and affect fuel-air ratio control repeatability. Burner manufacturers typically recommend draft controls be installed in applications where:

- Stack height exceeds 75 feet
- Multiple furnaces are connected to a single stack

## JC-22D "Floating" Draft Control Mode

- Direct Field Replacement for existing **JC-20F11AR2** and similar units
- Compatible with existing electric draft actuator, does not require feedback pots
- Uses proportional control to direct the damper open or closed until the draft returns to setpoint.

## JC-22D "Precise" Draft Control Mode

- Precise PID control
- "GAP" PID Draft Control uses a dual gain strategy (ie.: lower gain near setpoint, higher gain farther away from setpoint) to allow precise draft control without hunting due to draft pulsations.
- Firing rate feedforward allows the controller to instantly respond to changes in firing rate demand without waiting for the outlet pressure to deviate from the acceptable range. This is especially important in Induced Flue Gas Recirculation (IFGR) applications.
- Adjustable Start Position directs the outlet damper to 100% for purge and then closes the damper to a predetermined position for light-off. Boilers with very tall stacks, oversized ID fans, or wide turndown Low NOx burners may not be able to light-off with the outlet damper wide open.

## Automatic Draft Sequence

- Damper positioned for purge, light-off, post-purge and burner shutdown. To prevent pressurizing the boiler during startup, the draft damper opens immediately, and the burner fan start is delayed 0 - 30 seconds (adjustable). The damper is closed when the boiler is off-line to minimize energy waste.

## Low Draft Alarm Message and Contact

### Automatic Draft Control Increases Boiler Efficiency

- Reducing the air infiltration into the furnace reduces heat lost up the stack. Uncontrolled boiler draft results in a more negative boiler pressure and therefore more cold air being drawn into the boiler
- Maintaining a stable and optimum draft despite changes in ambient air temperature, wind velocities, firing rates, and flue pass sooting conditions allows the burner control systems to operate with less excess air. At a given F.D. fan inlet damper position, the air flow through the burner will change as boiler draft changes.



JC-22D Draft Controller

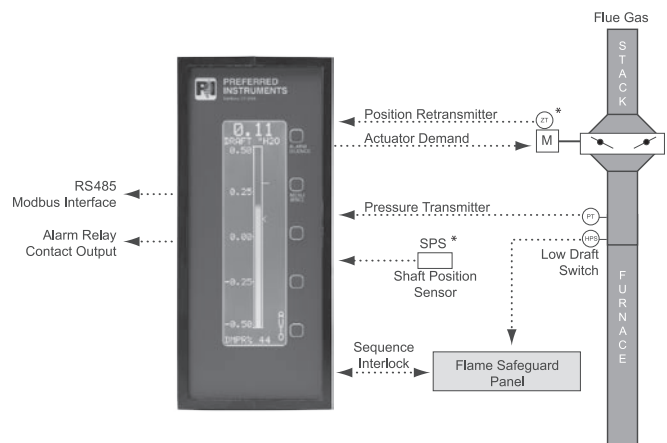

Draft Control General Arrangement

\*Not required for "floating" point draft control applications

## Description

The **JC-22D** Draft Monitor and Controller is a microprocessor-based draft controller, indicating instrument, and alarm monitor. The **JC-22D** directly accepts a 4-20 mADC draft transmitter signal, 120 VAC flame safeguard interface, and outputs a solid state switching (triac) or 4-20 mADC outlet damper actuator control signal. Draft is continuously displayed using a highly visible backlit LCD display. An intuitive bargraph display and alarm message provide clear boiler draft status. All adjustments can be made directly from the faceplate of the instrument by scrolling through user friendly, English language menus. The outlet

# DRAFT CONTROLLER

## Model JC-22D

damper may be controlled in "Auto" or "Manual" mode and will automatically sequence through the purge, light-off, post-purge and burner shutdown modes in response to flame safeguard system inputs. The **JC-22D** automatically positions the outlet damper according to burner operation based on either the field selectable "Floating" or "Precise Draft" Control modes.

### Specifications

#### Panel

Power Supply:	120 VAC, +/- 15%, 50/60Hz, 15 VA
Case Size:	8" H x 3.5" W x 7.5" D
Enclosure Type:	NEMA 4 faceplate
Ambient Temp.:	+32° to 122° F
Displays:	High Contrast LCD Display 4" high, 0.5% Resolution Bargraph
Bargraph Range:	-1.00 to +1.00" W.C.
Alarm Setpoints:	One (1) adjustable contact with adjustable time delay

#### Inputs

Draft Input:	4-20 mADC digital filtered
Firing Rate Input:	300 ohm (minimum) or 4-20 mADC
Discrete Input:	Five, Optically isolated 120 VDC, 10 mA load
Actuator Feedback:	300 ohm min feedback pot (required for GAP PID Control Mode)

#### Outputs

Relay Outputs:	Three SPDT Relays 10 A Resistive, 8 FLA, ½ HP, 120 VAC
Actuator Outputs:	One Triac pair, 2 FLA/24-120 VAC or 4-20 mADC
Network:	1200 - 38400 Baud; RS485 Modbus, ASCII or RTU

### Ordering Information

To order a "Floating" Draft Control System, specify the following:

- 1) Specify **Model JC-22D** Draft Controller with **Model JC-XMTR** Draft Range Transmitter Assembly
- 2) Specify **DM-2** Electric Rotary Actuator or **PL-2** Electric Linear Actuator
- 3) Alternately, Specify Model JC-22D Draft Controller and **Model E-Link** Draft Damper Assembly

To order a "Precise" Draft Control System, specify the following:

- 1) Specify **Model JC-22D** Draft Controller with **Model JC-XMTR** Draft Range Transmitter Assembly
- 2) Specify **SM** Electric Rotary Actuator Triac or **R-AL-2-3-P1-4-S2-0** Electric Linear Actuator (4-20 mA)
- 3) Alternately, Specify **Model JC-22D** Draft Controller and **Model E-Link** Draft Damper Assembly
- 4) Specify **Model SPS** Shaft Position Sensor (when required)

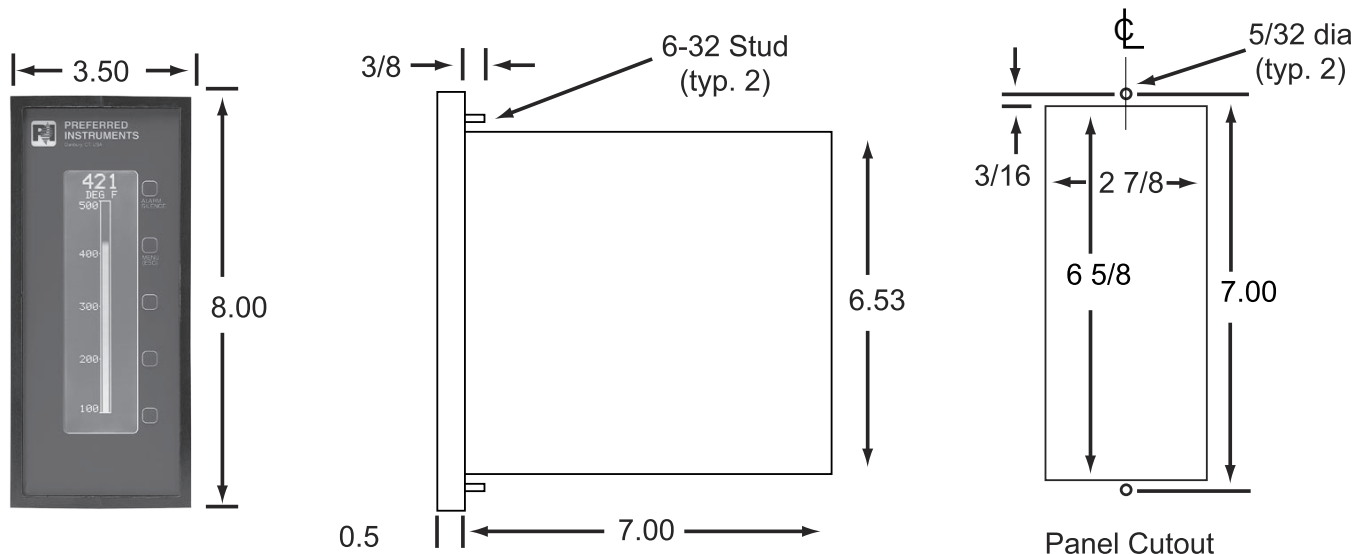

JC-22D Mounting and Clearance Dimensions

# DRAFT CONTROLLER

Model JC-22D

## Suggested Specifications

### 1. Application

Provide a self contained automatic sequence draft controller for each furnace. The controller shall be microprocessor-based and suitable for flush, panel mounting. Provide a field mountable 4-20 mADC pressure draft transmitter for measuring boiler outlet draft. Provide a high flue gas pressure (low draft) switch with 5 second delay for use in the Flame Safeguard Limit Circuit.

### 2. Draft Controller

The Controller shall continuously indicate furnace draft, draft setpoint and alarm setpoint on a highly visible backlit LCD display. The control shall provide both automatic and manual damper control. Provide an integral or separate 4", 0.5% resolution (minimum) bargraph display in engineering units with visual alarm indication. Provide a "High Boiler Pressure" alarm, "Alarm Silence" pushbutton and one 10 A alarm relay output. The housing shall be panel mountable, fully gasketed with NEMA 4 front face. All adjustments shall be made from the front panel display in engineering units. The controller shall include setup menus for easy operation, tuning and troubleshooting from the Controller faceplate. No external configuration tools shall be required.

### 3. Automatic Draft Sequence

The controller shall include an automatic draft sequence as follows: during burner "off" periods the draft control damper shall remain closed to hold residual heat within the boiler. On a call for burner operation the outlet damper shall be driven open for pre-purge. To prevent pressurizing the boiler, the burner fan shall start after a field adjustable time delay after starting to open the draft damper. The damper shall remain open for burner light-off. When the fuel valve opens, the draft control damper shall be released from the open position and modulate as required by the draft setpoint. During normal burner shut-down the damper shall be driven open during the post-purge period and then closed when the fan stops. Abnormal burner shut-down (safety lock-out of flame safeguard control) shall cause the damper to drive open where it shall remain until the flame safeguard system is reset. The controller shall interconnect with the flame safeguard system directly using 120 VAC signals.

### 4. Draft Damper Modulation

When the precise draft control mode is required, the controller shall provide boiler outlet damper modulating control based on characterizable firing rate feed-forward signal to assure stable draft during load changes and "GAP" PID Draft Control for improved stability. Provide a **Model SPS** firing rate feedback potentiometer as manufactured by Preferred Instruments, Danbury, CT, or firing rate output from the firing rate controller. The controller shall be capable of establishing an adjustable position for burner light-off. Each fuel shall have an independent light-off position. The controller shall not close the light-off contact output unless the damper is above the proper position and the pressure is below the starting draft setpoint. Alternately, the controller shall be field selectable to provide "Floating" draft control. When "Floating" draft control is selected, the controller shall provide proportional control of the boiler outlet damper to maintain boiler draft at setpoint using a 24 VAC, Triac positioning output.

### 5. Draft Range Transmitter and High Pressure Switch

Provide a draft range transmitter and high pressure (low draft) switch with time delay relay. Both shall be supplied with field mountable, dust-tight, splash-proof enclosures. A single draft connection shall be piped to -1" W.C. to +1" W.C. 4-20 mADC transmitter and an independent low draft switch. The low draft switch setpoint shall be field adjustable from +0.15" W.C. to +4.0" W.C. The low draft switch shall be mounted and wired to a pilot light so as to illuminate when the low draft switch activates and to a 5 second time delay relay so as to provide an isolated "Low Draft Cut-Out", 10 A contact for use in the Flame Safeguard Limit Circuit. The time delay feature helps avoid nuisance burner shutdowns due to momentary draft fluctuations.

### 6. Draft Damper Actuator (when required)

Provide an electric Draft Damper Actuator for each furnace. The actuator shall have adequate power to automatically position the damper and shall be suitable for control by the Draft Controller. The actuator shall be totally enclosed in a dust-tight housing; have integral, snap-action, travel limit and open proving switches, be capable of being stopped, started, or instantly reversed without loss of power or overloading. A double ended output shaft shall have an integral brake for precise positioning without backlash and rotate 90° in 30 seconds. When the precise draft control mode is selected, the actuator shall include an electrically isolated feedback potentiometer.

### 7. Draft Damper Assembly - Model E-Link (when required)

Provide a factory assembled stack damper assembly for each furnace. The draft damper shall be a dual opposed blade design, have 24" inside diameter [select from 12", 16", 20" or 24" diameter to match boiler outlet, consult factory for larger sizes], constructed of 10 gauge rolled steel. Non-opposed blade damper designs are not acceptable. Factory mount the draft damper actuator, draft range transmitter and time delayed, high pressure (low draft) cut-out assemblies (described in the above paragraphs) on the damper assembly. The damper actuator and damper assembly shall be stroked at the factory to ensure proper alignment. "Shipped Loose" components will not be accepted.

### 8. Communication

The Instrument shall include a RS485 Modbus network interface to communicate to a future Data Acquisition System (DAS) or Building Automation System (BAS).

### 9. Quality Assurance

The Instrument shall be manufactured and labeled in accordance with UL508 (CSA C22.2 #14 for use in Canada). Inspection and labeling shall be supervised by UL or other OSHA approved Nationally Recognized Test Lab (NRTL). The draft control system shall be a Preferred Instruments, Danbury, CT, **Model JC-22D** Draft Controller with **Model JC-22XMTR** Draft Range Transmitter Assembly or **JC-22D** Draft Controller and **E-Link** Draft Damper Assembly and **Model SPS** Shaft Position Sensor (when required).