

SMOKE OPACITY MONITOR

Model JC-30D

The Preferred Instruments **JC-30D** Smoke Opacity Monitoring System assures an accurate measurement of the smoke emissions from boilers, incinerators, kilns, and similar sources of intermittent, visible emissions. Typical applications include commercial buildings, schools, hospitals, apartment complexes, and industrial plants. The information provided encourages increased emphasis on clean, efficient combustion and effective air pollution control.

Automatic Calibration when Burner cycles off

- Prevents Nuisance Trips

Early Warning Message and Relay Contact

- Deteriorating combustion conditions can be detected early before developing into major problems.

Burner Safety Shutdown Message and Relay Contact

- Dangerously high opacity is an indication of an unstable flame condition.

Single pass design, no moving parts

High Visibility Bargraph and Numeric Display

Three Alarm Sequences (field selectable):

- Standard
- NYC BAR
- Wood / Coal Overfire Air Fan

NEMA 4 Front Panel

Flexible Communications for Data Logging:

- 4-20 mADC Opacity Re-transmission
- RS485 Modbus Interface

Automatic Calibration

The **JC-30D** includes a 120 VAC input that monitors the burner fan starter coil and initiates an Automatic Calibration cycle whenever the burner fan stops running (ensuring a clear stack condition). This prevents nuisance burner trips due to dust buildup. "WARNING: CLEAN LENSES NOW" is displayed when the dust level is high. At the completion of the Calibration Cycle, the **JC-30D** turns off the light source until the fan restarts, extending the life of the bulb. A Calibration Cycle can also be manually initiated from the **JC-30D** Menu (after a lens cleaning, re-alignment, etc).



JC-30D shown in "SHUTDOWN" condition (alarm message & reset pushbutton visible)

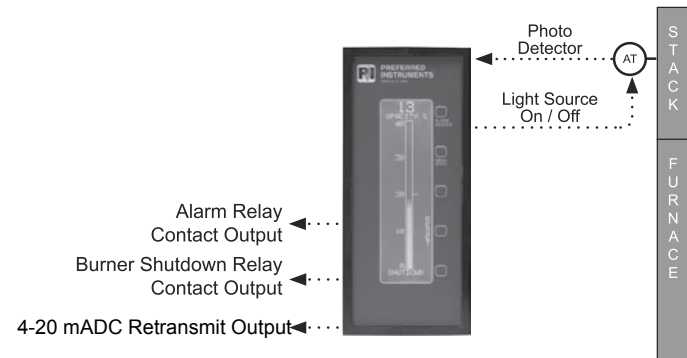

Typical JC-30D Arrangement

SMOKE OPACITY MONITOR

Model JC-30D

Description

The **JC-30D** Smoke Opacity Monitor is a microprocessor-based Indicating Instrument with a smoke duct mounted optical sensing assembly. The system provides a continuous opacity readout, alarm indication and shutdown capability. The smoke opacity percent is continuously displayed using a highly visible backlit LCD display. An intuitive bargraph display and alarm message provides rapid recognition of combustion conditions. All adjustments can be made directly from the faceplate of the instruments by scrolling through user-friendly, English language menus.

The Optical Sensing Assembly consists of a Light Source and Light Sensor. These units are mounted on opposite sides of the smoke duct with the light beam focused from the source side to the sensor side. Smoke passing through the light beam reduces the intensity being received by the sensor. A signal is transmitted to the Indicating Instrument which continuously displays the percent smoke opacity and provides the alarm and control functions. This reliable single pass design requires no moving parts or complicated optical devices.

The Light Source uses a low voltage, pre-focused, sealed beam lamp at a projection angle of 5° to reduce scattered light inaccuracies. The Light Sensor includes a solid state, photopically filtered photoelectric cell. The unit's built-in optical "bull's eye" and variable blink rate LED assist in alignment verification. Lenses are specially designed for easy cleaning without dismantling the installed assembly. The JC-30D is not recommended for high temperature, refractory lined breechings. Please contact factory for details.

Operation

The indicating instrument continuously displays the percent smoke opacity and provides the following alarm and control sequences. Typically the **JC-30D** alarm relay activates an external alarm bell or horn, and the shutdown relay is used to shut down the burner.

"Standard" Operating Sequence

Smoke Opacity exceeds setpoint: Bargraph blinks and "ALARM" message appears.

After 20 seconds "smoke-puff" delay: Alarm relay (K1) contact activates, the remote alarm bell or horn is activated. Pressing the Alarm Silence button deactivates (K1) relay and the external bell or horn.

Smoke Opacity continues for 120 seconds (adjustable): The shutdown relay (K2) activates in manual reset mode, "SHUTDOWN" message appears, and the (K1) relay re-activates. When the smoke opacity condition clears, the **JC-30D** RESET pushbutton must be pressed to reset the shutdown relay in order for the burner to restart.

Smoke Opacity returns to normal: "ALARM" message disappears.

"NYC BAR" Sequence

This sequence is similar to the Standard Operating Sequence (above), but conforms to the New York City D.E.P. Bureau of Air Resources requirements. The (K1) relay activates instantly and the (K2) relay delay is fixed at 120 seconds (not adjustable). The 190712 Light Sensor Alarm Test filter complies with NYC BAR requirements.

"WOOD / COAL" Overfire Air Fan Sequence

This sequence is used with stoker fired boilers. See the Standard Operating Sequence (above) for (K1) relay and Alarm Silence button operation. The (K2) relay is used to reduce opacity by activating an overfire air fan or damper. When opacity has been above setpoint for 15 seconds (adjustable) the overfire air relay (K2) activates and a "FAN ON" message appears. When the smoke clears and drops below setpoint, the (K2) relay remains activated for an additional 180 seconds (adjustable) to help prevent a re-occurrence of excessive smoke.

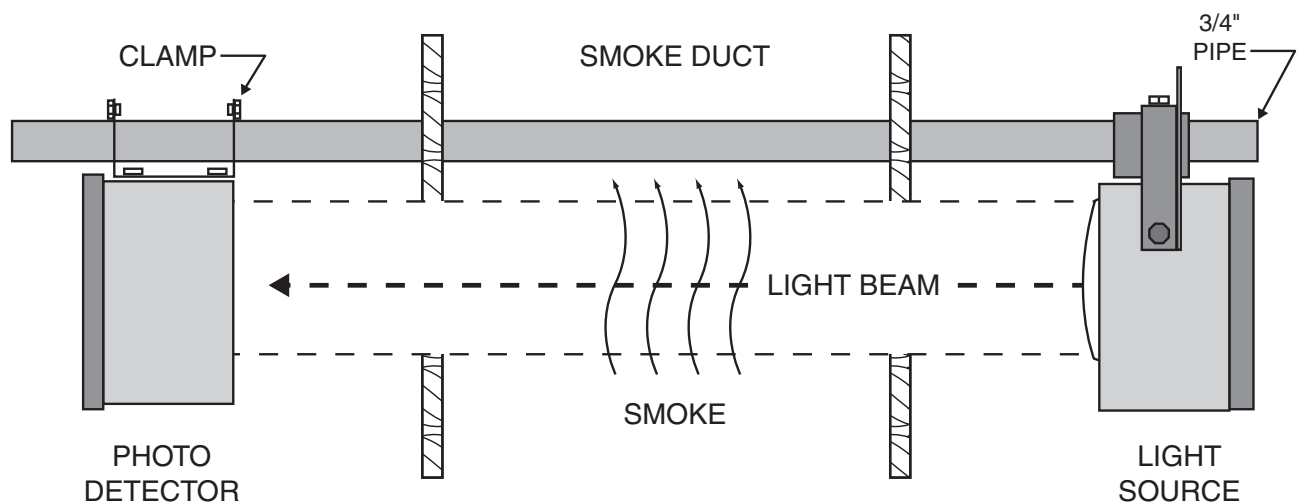

SMOKE OPACITY MONITOR

Model JC-30D

Specifications

Panel

Power Supply:	120 VAC 50/60Hz, 15 VA
Case Size:	8" H x 3.5" W x 7.5" D
Enclosure Type:	NEMA 4 faceplate, Flush Mounting
Ambient Temp.:	+32° to +122° F ambient
Digital:	High Contrast LCD Display
	4" high, 0.5% Resolution Bargraph
Status Messages:	ALARM, SHUTDOWN, WARNING: CLEAN LENSES NOW EXCESS LIGHT
Alarm Setpoints:	Adjustable 5-50%

Light Source and Light Sensor

Calibration:	Automatic, Off-Line
Spectral Response:	Photopic Peak and mean within 500-600nm
Angle of Projection:	<5°
Operational Error:	<5%
Span Drift:	<2%
Zero Drift:	<2%
Calibration Error:	<1% (Linearity)
Response Time:	<10 seconds for 95% change in opacity
Sighting Distance:	1 to 8 foot smoke duct. 3 to 10 foot optical path length
Wiring Distance:	500 ft. max (16 ga. wire) 250 ft. max (20 ga. wire)
Sensor Housing:	¾" pipe mount

Outputs

Relay Outputs:	Two SPDT Relays 10 A resistive, 8 FLA, ½ HP, 120 VAC
Retransmission Output:	4-20 mADC, 650 ohm load max
Network Output:	1200-38400 baud, RS485 Modbus, ASCII or RTU

Ordering Information

1. JC-30D Monitor, 190711 Light Source, 190712 Light Sensor, and two Light Sensor Shields 190713 are required for complete system.

Optional Accessories

1. Pressure cap set with purge and non-purge fittings (107226P)
2. Pressure cap set with integral blower (2 blowers) (190275A)
3. Remote audible / visual alarm (SDA-VB)
4. Alarm bell, 6" dia., 85 db (SDA-B6)
5. Recorder-31 day, 2 ¼" strip chart (R88-E5)

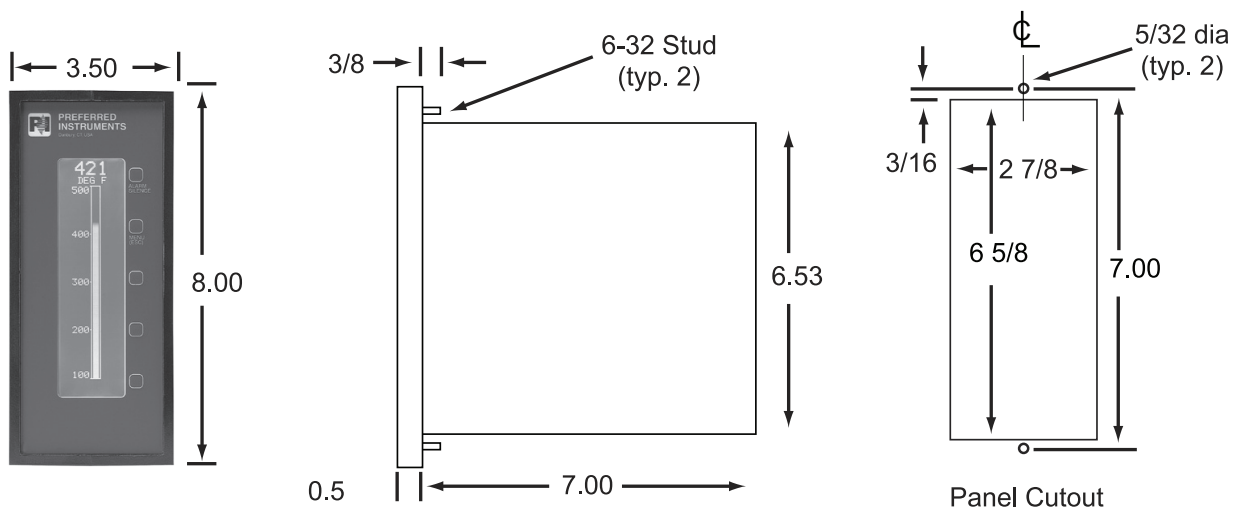

SMOKE OPACITY MONITOR

Model JC-30D

1. Application

Provide a Smoke Opacity Monitor for each furnace. The smoke monitor shall consist of a light source, solid-state optical detector, and microprocessor-based alarm and indicating instrument. The instrument shall provide a smoke opacity percent display in engineering units, early deteriorating combustion conditions warning indication, burner Safety Shutdown indication and relay contacts. The instrument shall continuously indicate smoke density on a highly visible backlit LCD display. Provide an integral or separate 4", 0.5% resolution (minimum) bargraph display in engineering units with visual alarm setpoint indication. Provide an "Alarm Silence" and "Manual Reset" pushbutton and two 10 A relays. The housing shall be panel mountable, fully gasketed with NEMA 4 front face. All adjustments shall be made from the front panel display in engineering units. No external configurator or laptop shall be required. The "Standard" Operating Sequence shall be as follows: when smoke density exceeds setpoint, the bargraph shall flash, and an "Alarm" message shall appear. After a 20 second "smoke-puff" delay the "Alarm" relay contact closes the circuit for the remote alarm device. Pressing the "Alarm Silence" pushbutton resets the alarm relay to silence the alarm device. If the smoke density reduces below the setpoint within 120 seconds (adjustable), the bargraph stops flashing and the "Alarm" message disappears. If the smoke density exceeds the setpoint for 120 seconds or more, the "Shutdown" message shall appear, the "Alarm" relay re-closes and manually reset "Shutdown" relay contact open to shut down the violating burner. Pressing the "Alarm Silence" pushbutton resets the alarm relay to silence the alarm device. When the smoke density then falls to below the setpoint, the "Shutdown" message will remain on and the "Shutdown"

relay will remain in the manual reset mode. With smoke opacity cleared, pressing the "Reset" pushbutton will reset the system, the "Shutdown" message will disappear, and the "Shutdown" relay will reset to permit normal burner operation. In order to avoid nuisance burner trips due to dust build-up on the light source and sensor, the instrument must include an automatic, unattended re-calibration cycle whenever the burner fan stops running (ensuring a clear stack condition). The optical sensing unit lenses shall be designed to accommodate regular cleaning without dismantling the installed assembly. Light Source and Detector will sight 100% of the effluent path length. Light Source will utilize a pre-focused sealed beam lamp with a maximum 5 degree projection angle. Photo Detector shall include a photopically filtered, solid state photo cell and alignment verification bulls eye.

2. Communication

The Instrument shall include a RS485 Modbus network interface and a 4-20 mADC re-transmit output to communicate to a future Data Acquisition System (DAS) or Building Automation System (BAS).

3. Quality Assurance

The Instrument shall be manufactured and labeled in accordance with UL508A requirements (CSA C22.2 #14 for use in Canada). Inspection and labeling shall be supervised by UL or other OSHA approved Nationally Recognized Test Lab (NRTL). The draft control system shall be a Preferred Instruments, Danbury, CT, **Model JC-30D**.