

- Automatic Calibration when Burner cycles off
- Prevents Nuisance Trips
- Early Warning and Safety Shutdown Relays
- Single pass design, no moving parts
- High Visibility Bargraph and Numeric Display
- Three Alarm Sequences (field selectable):
- Standard
- NYC BAR
- Wood / Coal Overfire Air Fan
- NEMA 4 Front Panel
- Flexible Communications for Data Logging:
- 4-20 mA Opacity Re-transmission
- RS-485 Modbus Interface

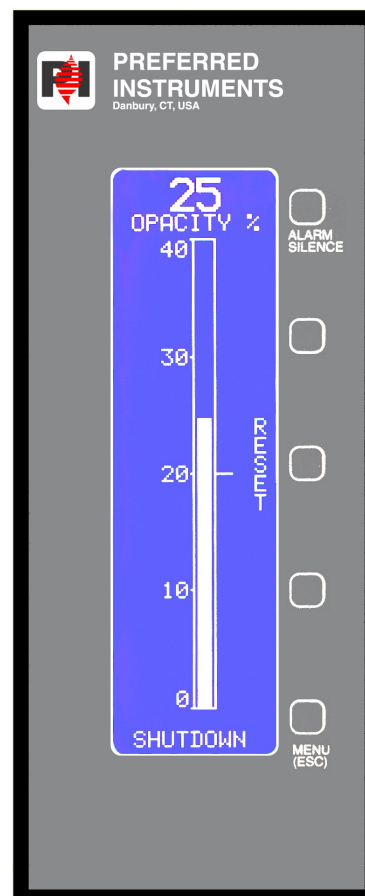

JC-30D shown in “SHUTDOWN” condition (alarm message & reset pushbutton visible)

Application

The Preferred Instruments JC-30D Smoke Opacity Monitoring System assures an accurate measurement of the smoke emissions from boilers, incinerators, kilns, and similar sources of intermittent, visible emissions. Typical applications include commercial buildings, schools, hospitals, apartment complexes, and industrial plants. The information provided encourages increased emphasis on clean, efficient combustion and effective air pollution control. Deteriorating combustion conditions can be detected early before developing into major problems.

Automatic Calibration

The JC-30D includes a 120 Vac input that monitors the burner fan starter coil, and initiates an Automatic Calibration cycle whenever the burner fan stops running (insuring a clear stack condition). This prevents nuisance burner trips due to dust build-up. “WARNING: CLEAN LENS NOW” is displayed when the dust level is high, or “DIRTY, NOT CALIBRATED” is displayed when re-calibration is no longer possible. At the completion of the Calibration Cycle, the JC-30D turns off the light source until the fan re-starts, extending the life of the bulb.

A Calibration Cycle can also be manually initiated from the JC-30D Menu (after a lens cleaning, re-alignment, ...)

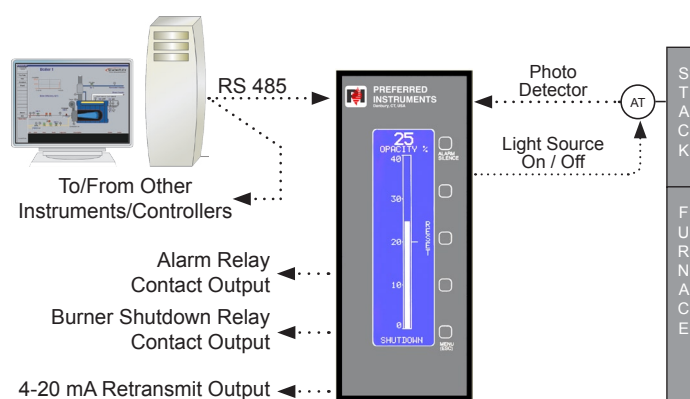

Typical Arrangement

Description

The JC-30D Smoke Opacity Monitor is a microprocessor-based **Indicating Instrument** with a smoke duct mounted optical sensing assembly. The system provides a continuous opacity readout, alarm indication and shutdown capability. The smoke opacity percent is continuously displayed using a highly visible backlit LCD display. An intuitive bargraph display and alarm messages provide rapid recognition of combustion conditions. All adjustments can be made directly from the faceplate of the instruments by scrolling through user friendly, English-language menus.

The **Optical Sensing Assembly** consists of a Light Source and Photo Detector. These units are mounted on opposite sides of the smoke duct with the light beam focused from the source side to the detector side. Smoke passing through the light beam reduces the intensity being received by the detector. A signal is transmitted to the Indicating Instrument which continuously displays the percent smoke opacity and provides the alarm and control sequence. This reliable single pass design requires no moving parts or complicated optical devices.

The **Light Source** uses a low voltage, pre-focused, sealed beam lamp at a projection angle of 5° to reduce scattered light inaccuracies. The Photo Detector includes a solid state, photopically filtered photoelectric cell. The unit's built-in optical "bull's eye" assists in alignment verification. Both light source and detector housings are black enamel over durable steel construction. Lenses are specially designed for easy cleaning without dismantling the installed assembly.

Operation

The indicating instrument continuously displays the percent smoke opacity and provides the following alarm and control sequences. Typically the JC-30D alarm relay activates an external alarm bell or horn and the shutdown relay is used to shut down the burner.

'Standard' Operating Sequence

Smoke Opacity exceeds setpoint: Bargraph blinks and "ALARM" message appears.

After 20 seconds "smoke-puff" delay: Alarm relay (K1) contact activates, the remote alarm bell or horn is activated. Pressing the Alarm Silence button de-activates (K1) relay and the external bell or horn.

Smoke Opacity continues for 120 seconds (adjustable): The shutdown relay (K2) activates in manual reset mode, "SHUTDOWN" message appears, and the (K1) relay re-activates. When the smoke opacity condition clears the JC-30D RESET pushbutton must be pressed to reset the shutdown relay in order for the burner to re-start.

Smoke Opacity returns to normal: "ALARM" message disappears.

'NYC BAR' Sequence

This sequence is similar to the Standard Sequence (above), but conforms to the New York City D.E.P. Bureau of Air Resources requirements. The (K1) relay activates instantly and the (K2) relay delay is fixed at 120 seconds (not adjustable). In addition, the 190712 Light Sensor with Alarm Test filter must be installed to comply with NYC BAR requirements.

'WOOD / COAL' Overfire Air Fan Sequence

This sequence is used with stoker fired boilers. The (K2) relay is used to reduce opacity by activating an overfire air fan or damper. See the Standard Sequence (above) for (K1) relay and Alarm Silence button operation. When opacity has been above setpoint for 15 seconds (adj.) the Overfire Air relay (K2) activates and a "FAN ON" message appears. When the smoke clears and drops below setpoint, the (K2) relay remains activated for an additional 180 seconds (adj.) to help prevent a re-occurrence of excessive smoke.

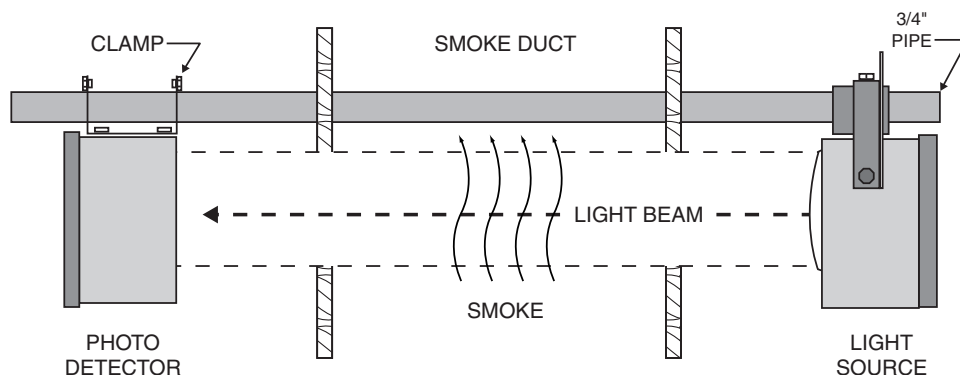

Typical Photo Detector and Light Source Arrangement

Suggested Specification

The Smoke Monitor shall consist of a light source, solid-state optical detector, and microprocessor based indicating/alarm instrument. The instrument shall indicate smoke density on a highly visible backlit LCD display. Provide an integral or separate 4 inch, 0.5% resolution (minimum) bargraph display in engineering units with visual alarm setpoint indication. The instrument shall include alarm messages as follows: When smoke density exceeds set point, the bargraph shall flash, an "ALARM" message shall appear and automatic reset alarm relay contact closes the circuit for the remote alarm device. If the smoke density reduces to below the setpoint within 120 seconds, and the alarm silence pushbutton is pressed the bargraph stops flashing, the "Alarm" message disappears, and the alarm relay contacts opens to de-energize the remote alarm device. If the smoke density exceeds the setpoint for 120 seconds or more, the "Alarm" message remains on, the alarm relay re-closes and manually reset burner control relay contacts open to shut down the violating burner. When the smoke density then falls to below the setpoint, the "Alarm" message will remain on and relays will remain in the manual reset mode. With smoke opacity cleared, depressing the RESET pushbutton will reset the system to normal operation. The "Alarm" message will disappear, the alarm relay will reset to silence the alarm, and the control relay will reset to permit normal burner operation. Provide an integral or separate alarm silence pushbutton and required relays. In order to avoid nuisance burner trips due to dust build-up on the light source and sensor the instrument must include an automatic, unattended re-calibration cycle whenever the burner fan stops running (insuring a clear stack condition).

The optical sensing unit lenses shall be designed to accommodate regular cleaning without dismantling the installed assembly. Light Source and Detector will sight 100% of the effluent path length. Light Source will utilize a pre-focused sealed beam lamp with a maximum 5 degree projection angle. Photo Detector shall include an photopically filtered, solid state photo cell and alignment verification bulls eye. Instrument shall be a Preferred Instruments, Danbury, CT, Model JC-30D.

Specifications

Power Supply:	120Vac 50/60Hz, 15VA
Ambient Temp.:	+32 to +122° F ambient
Digital:	High Contrast LCD Display 240 x 64 pixel 4" high, 0.5% Resolution Bargraph
Status Messages:	ALARM, SHUTDOWN, WARNING: CLEAN LENS NOW DIRTY NOT CALIBRATED EXCESS LIGHT
Alarm Setpoints:	Adjustable 5-50%
Relay Outputs:	Two SPDT Relays 10 A resistive, 8 FLA, ½ HP, 120 Vac
Output:	4-20 mA, 650 ohm load max and RS-485 Modbus Interface
Calibration:	Automatic, Off-Line
Spectral Response:	Photopic Peak and mean within 500-600nm.
Angle of Projection:	<5°
Operational Error:	<5%
Span Drift:	<2%
Zero Drift:	<2%
Calibration Error:	<1% (Linearity)
Response Time:	<2 seconds for 95% change in opacity
Sighting Distance:	1 to 8 foot smoke duct. 3 to 10 foot optical path length
Wiring Distance:	500 ft. max (16 ga. wire) 250 ft. max (20 ga. wire)
Enclosure:	NEMA 4 faceplate Flush Mounting
Sensor Housing:	¾" pipe mount

Ordering Information

1. **JC-30D-X** (Standard Photo Detector)
2. **JC-30D-FX** (NYC-DAR Photo Detector)

Optional Accessories

1. Positive pressure duct sealing caps (**107226P**)
2. Remote audible / visual alarm (**SDA-VB**)
3. Alarm bell, 6" dia., 85 dB (**SDA-B6**)
4. Recorder-31 day, 2 ¼" strip chart (**R88-E5**)

