

POWER ARM LINEAR ACTUATOR

Model PL, R-AL & R-ALP

- Adjustable 1" - 6" travel electric actuator
- 100 or 200 lbs output thrust
- Designed for modulation service
- Self-locking drive system to hold in last position
- Two infinitely adjustable auxiliary limit switches
- Isolated position feedback available with R-AL & R-ALP Models
- Integral 4-20 mADC positioner circuit board available with R-ALP Models

The Preferred Instruments series **PL, R-AL** and **R-ALP** "Power Arm" actuators are self-contained, electro-mechanical, linear actuators for use in remotely controlled manual or fully automatic control systems. The units may be started, stopped or instantly reversed at any point within the stroke without damage, overheating or loss of power. The "Power Arm" actuator has a solid performance history earned by years of continuous operation in thousands of unattended boiler room combustion installations.

Application

The "Power Arm" actuators provide a positive linear thrust for positioning dampers, louvers, jackshaft mechanisms, rotary valves, or other mechanisms. The R-AL and R-ALP are used for closed loop positioning control in a combustion control system application while the PL is used for 3-wire floating control in boiler draft control cases. Though these actuators are generally used in positioning applications, they are equally suited for on/off control.

Operation

In response to a SPDT control switch with a neutral position, (or analog input signal on R-ALP Models) a reversible gear motor (A) rotates an Acme threaded lead screw (B) to drive a travelling nut (C) and extend or retract the actuator ram (D). Sealed, snap-action switches (E) are opened by ram mounted cams (I & J) to stop the motor and positively limit ram travel. The standard actuator includes two normally open auxiliary switches (F) that trip immediately prior to the full open or closed ram position. A potentiometer (not shown) provides a ram position feedback signal in the R-AL and R-ALP Models.

Installation

Stationary or pivot mounting is available. Stationary mounting uses base (G) and stabilizing bracket (H). Attached to the ram eye (K) is a clevis that pivots as the ram extends and retracts. Pivot mounting uses only base (G). The ram eye and clevis are replaced by a length of 1/2" pipe threaded into the ram end. As the ram extends and retracts, the actuator is free to pivot on the base. Pivot mounting permits the use of straight line, push-pull linkage that reduces ram friction with resultant prolonged ram and bearing life.



Power Arm Linear Actuator

Specifications

- Power:** 120 VAC, 50/60Hz, 60VA
Ambient Temp.: 150° F (65° C) Maximum
Input: Switching SPDT or floating contacts (Models PL & R-AL), or 4-20 mADC, 0-5VDC, 0-1000 ohms or 0-135 ohms (Model R-ALP).
Load: 100 lbs. or 200 lbs. thrust
Stroke: 1" - 6" adjustable
Speed: 6" in 30 or 60 seconds
Auxiliary Switches: Two integral, enclosed, 15A, 1/8 HP @ 120 VAC (switches available on PL & R-AL)
Position Feedback: Precision potentiometer, 1000 ohm on Models R-AL & R-ALP (consult factory for other output values)
Manual Operation: Handwheel (optional on PL & R-AL)
Linkage: Ram eye, catalog number 20040 included; connecting linkage optional
Motor: Sealed, permanently lubricated, continuous duty, capacity start and run, 3 wire reversible
Dimensions: 6 7/8" H x 11 7/8" L x 8 3/4" D
Enclosure: 14 gauge stainless steel, fully gasketed
Installation: Stationary or pivot mounting

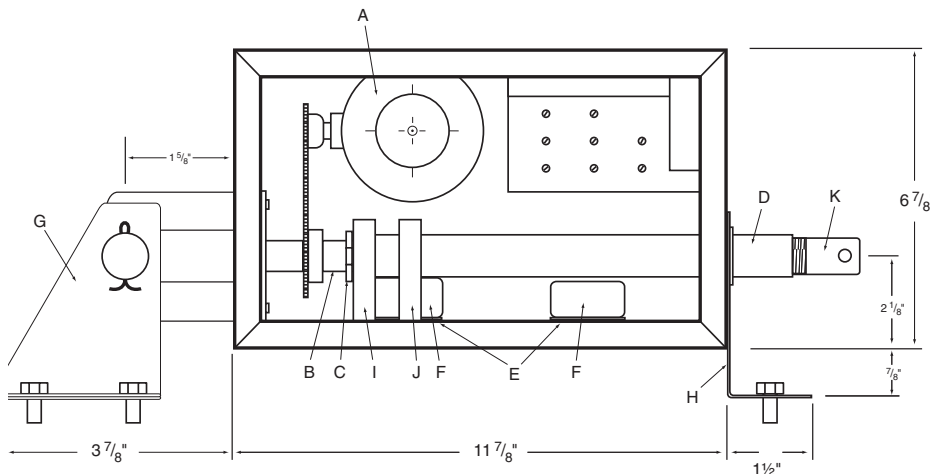

POWER ARM LINEAR ACTUATOR

Model PL, R-AL & R-ALP

Suggested Specifications

The actuator shall be totally enclosed, have a six inch stroke and 100 lbs (200 lbs) of push or pull thrust. The drive mechanism shall include a permanently lubricated, continuous duty rated, ball bearing type gear motor to drive an Acme threaded lead screw, travelling nut and thrust ram. The actuator shall be installed so as to pivot on its base as the ram extends and retracts. Linkage shall include an adjustable drive rod and cast iron crank arm. The actuator shall be Preferred Instruments, Danbury, CT, **Model PL, R-AL** or **R-ARP**.

Ordering Information

Actuator:

To order the basic model with switched inputs, specify the catalog number as follows:

PL-2-B3 200 lbs., 60 second travel speed, 120 VAC switching input actuator, two auxiliary limit switches and ram eye, swivel and stabilizing brackets (-W to include Hand Wheel).

PL-2-3-B3 100 lbs., 30 second travel speed, 120 VAC switching input actuator, two auxiliary limit switches and ram eye, swivel and stabilizing brackets (-W to include Hand Wheel).

To order the model with switched input and position feedback, specify the catalog number as follows:

Catalog No.: R-AL-2- [3/6] -P [1/2] - [4/X] - S2 - [0/W]

100 lbs., 30 sec. 3
200 lbs., 60 sec. 6

Auxiliary Potentiometer:

1 Auxiliary pot. 1
2 Auxiliary pot. 2
0 - 1000 ohm (std.) 4
other, consult factory X

Auxiliary Switches:

2 Auxiliary Switches 2
None 0
Hand Wheel W

To order the positioner model with analog or potentiometer input and position feedback, specify the catalog number as follows:

Catalog No.: R-ALP- [3/6] - [0/3/4/8] - P [0/4/5/X]

100 lbs., 30 sec. 3
200 lbs., 60 sec. 6

Input Signal:

4 - 20 mADC 0
0 - 5 VDC 3
0 - 1000 ohms 4
0 - 135 ohms 8

Aux. Position Feedback:

None 0
0 - 1000 ohm aux. pot 4
0 - 5 VDC 5
Other, Consult Factory X

Linkage:

Specify: Lever arm (catalog # 20054) and extension drive rod assembly (catalog # 107232). Order extra Clevis (catalog # 20021) for stationary mounting.

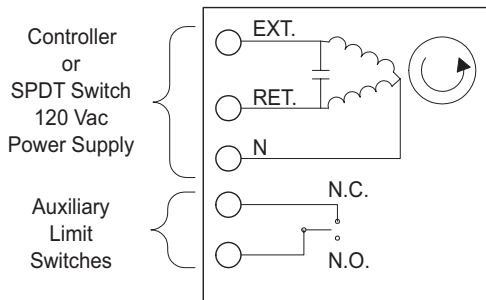

**Linear Actuator Model PL
Simplified Wiring Diagram**

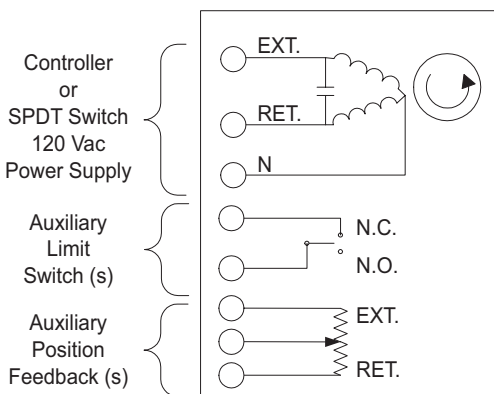

**Linear Actuator Model R-AL
Simplified Wiring Diagram**

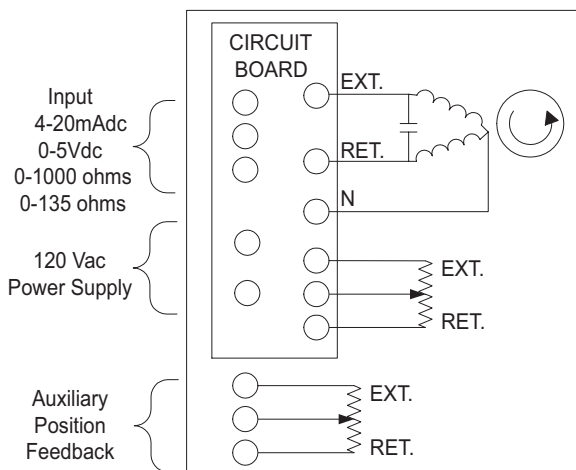

**Linear Actuator Model R-ALP
Simplified Wiring Diagram**