

WIRE FLOAT LEVEL SENSOR

Model TG-EL-WF (for use with TG-EL-D3 , TG-EL-D4A, or TG-EL-D5 Tank Gauges)

- Only 14" clearance required between the flange & overhead obstructions
- No. 2 through No. 6 fuel oil

The **TG-EL-WF Wire Float Level Sensor** is extremely accurate, easy to install, and ideal for low "Head Room" installation applications. The float is connected via a flexible stainless steel cable to a multi-turn, take-up reel within the sensor head. The flexible cable and the flanged tank connection allow rapid installation, even in restricted spaces. An integral test mechanism permits high level alarm and full tank calibration checks without removing the sensor from the tank. Suitable for all fuel oils, including No. 6.

Suggested Specifications

Provide a float type level sensor to provide accurate level monitoring that is unaffected by changes in the specific gravity of the tank liquid, and is suitable for use with non-corrosive fluids and fuels up to and including No. 6 fuel oil. The level sensor shall consist of a NEMA 6P rated, 1/4" cast aluminum head, connected to a float assembly by a flexible stainless steel cable. The sensor head assembly shall mount to the tank through a standard 4" 125/150 lb. flat face flange opening, with standard bolt pattern and must be capable of operating in a submerged manhole environment without damage. The unit shall be capable of easy installation and maintenance with only 14" of clearance between the flange and any overhead obstructions. The sensors operation shall be unaffected by internal tank obstructions located outside of a 14" diameter cylinder extending from the top of the tank to the bottom, and centered on sensor's mount. Tank gauge calibration shall be possible at any tank fluid level (empty, part full or full). The sensor shall include an external test mechanism to allow overfill alarm and full tank calibration checks without removal of the sensor from the tank. Tests that electronically simulate a high tank level, instead of physically moving the float, are not acceptable. The level sensor shall be Preferred Utilities Mfg. Corp., Danbury, CT, **Model TG-EL-WF**.

Specifications

Operation:	Wire Float
Float Test Mechanism:	External
Enclosure:	Aluminum, submersible, NEMA 4
Liquid Depth:	WF-12- 84" - 145" WF-7 - 36" - 84"
Accuracy:	+/- 0.2% FS for model WF-12 +/- 0.3% FS for model WF-7
Sensor Cable:	3 wire, shielded, suitable for direct burial or conduit installation, maximum 800 feet
Splice Kit:	Probe type
Tank Pressure:	5 PSIG maximum
Fluid Temperature:	180° F maximum
Sensor Head Temp:	-20° to 120° F maximum
Tank Contents:	All Oils (No. 1 thru No. 6) and non-corrosive liquids



TG-EL-WF Level Probe

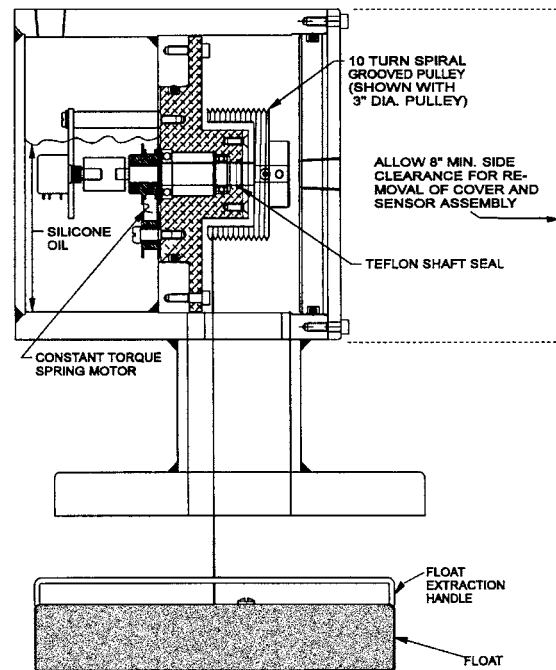

TG-EL-WF Level Probe
(Side-view section)

Wetted Parts:	Aluminum, Nylon, Buna N, Stainless Steel
Float Clearance:	6 3/4" radius around vertical centerline
Mounting:	4", 125 lb. flat faced flange

Ordering Information

Catalog Number: **TG-EL-WF**
Order with **TG-EL-D5, TG-EL-D4A, or TG-EL-D3** tank gauges