

SEMI-AUTOMATIC FUEL OIL TRANSFER PUMP SET

- **Loop or Day Tank Fuel Oil Transfer System**
 - No. 2 or No. 4 Fuel Oil
 - Flows from 20 to 2200 GPH
 - Industrial type Cast Iron Gear Pumps
- **Semi-Automatic Control**
 - Lead pump selection
 - Automatic start on "Call for Operation" from a single contact or 2 float level probe for pump "On" and "Off" contacts
 - Factory mounted and wired control cabinet

The **Semi-Automatic Transfer Pump Set** provides both manual "On" or "Off" operation or automatic operation in response to a "Call for Operation".

The **Semi-Automatic Transfer Pump Set** is a factory packaged, pre-engineered, pre-wired and pre-plumbed system that includes pumps, industrial motors and accessories. These systems are shipped to the job site, requiring only external fluid and electrical connections ensuring undivided responsibility of delivering fuel at the selected flow.

Standard Equipment

- Two "Hand-Off-Auto" switches
- Two "Pump On" indicators
- "Lead Pump" switch
- "Power On" indicator
- Two magnetic motor starters with overload protection
- Two motor circuit breakers
- Two pump & motor assemblies
- Two relief valves, two check valves and four ball valves
- Two simplex inlet strainers
- Inlet compound pressure gauge
- Discharge pressure gauges
- Three gauge isolation valves
- Base assembly

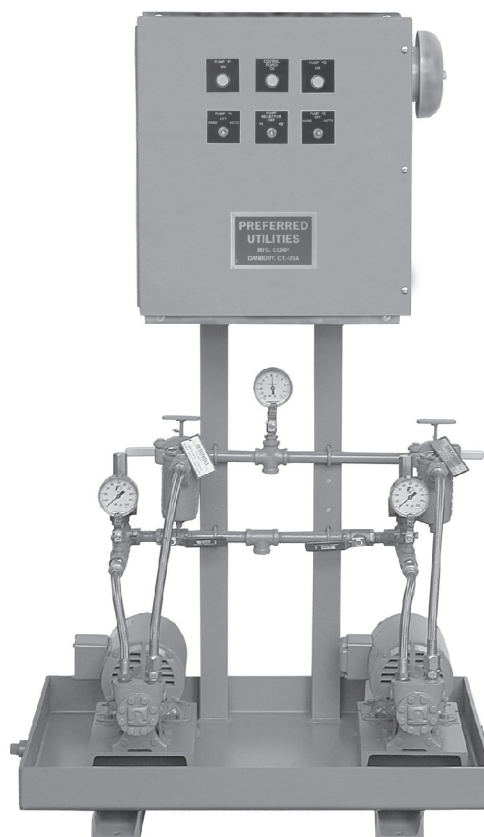

Semi-Automatic Fuel Oil Transfer Pump Set

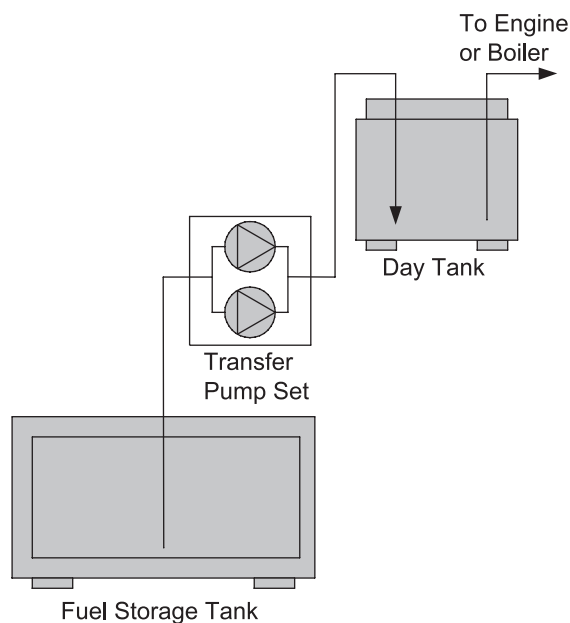

Semi-Automatic Pump Set Application Example

SEMI-AUTOMATIC FUEL OIL TRANSFER PUMP SET

Specifications

- Motor Power: 120, 208, or 230 Vac 1 phase or
208, 230, or 460 Vac 3 phase
- Control Circuit Power: 120 Vac 1 phase. Separate feed is required when selected motor voltage is other than 120 Vac
- Fluid: No. 2 or No. 4 Fuel Oil is standard. Consult factory for other fuel types
- Pump: Bi-rotational, positive displacement type with cast iron housings and self-adjusting mechanical seals
- Motors: Base mounted, Open Drip-Proof (ODP) construction
- Strainer: Simplex 1/2", 1", 1 1/2", or 2" (according to inlet line size) complete with 40 mesh basket

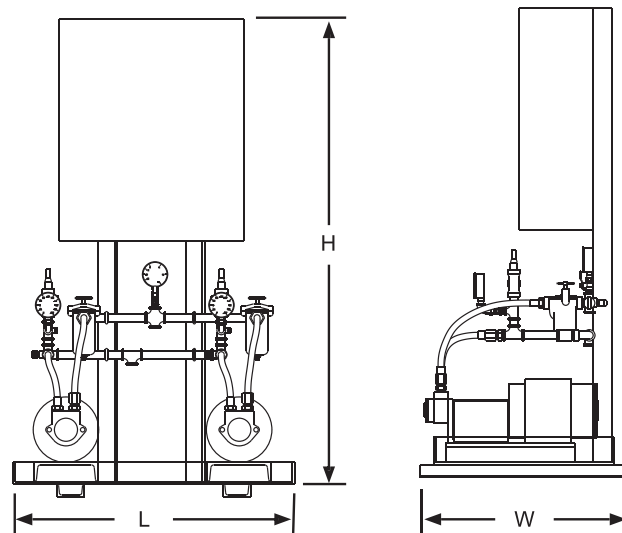

Size	G.P.H. Oil #2 / #4	P.S.I.	Motor				Dimension			Connection Size		
			R.P.M.	H.P.	Voltage	Phase	L.	W.	H.	Inlet	Outlet	Relief Valve
101	20 / 23	100	1725	1/3	120, 208 or 230	1	30 1/2"	22 1/2"	51"	1/2"	1/2"	1/2"
	23 / 23	50	1725	1/3	120, 208 or 230	1	30 1/2"	22 1/2"	51"	1/2"	1/2"	1/2"
102	27 / 33	100	1725	1/3	120, 208 or 230	1	30 1/2"	22 1/2"	51"	1/2"	1/2"	1/2"
	32 / 33	50	1725	1/3	120, 208 or 230	1	30 1/2"	22 1/2"	51"	1/2"	1/2"	1/2"
103	80 / 93	100	1725	1/3	120, 208 or 230	1	30 1/2"	22 1/2"	51"	1/2"	1/2"	1/2"
	86 / 95	50	1725	1/3	120, 208 or 230	1	30 1/2"	22 1/2"	51"	1/2"	1/2"	1/2"
104	145 / 155	100	1725	1/2	208, 230 or 460	3	30 1/2"	22 1/2"	51"	1/2"	1/2"	1/2"
	155 / 164	50	1725	1/2	208, 230 or 460	3	30 1/2"	22 1/2"	51"	1/2"	1/2"	1/2"
105	282 / 285	50	1725	3/4	208, 230 or 460	3	30 1/2"	22 1/2"	51"	1/2"	1/2"	1/2"
106	277 / 285	100	1140	1	208, 230 or 460	3	30 1/2"	22 1/2"	51"	1/2"	1/2"	1/2"
201	340 / 415	50	1140	1/2	208, 230 or 460	3	65 1/2"	30 1/2"	58"	1"	1"	1/2"
202	300 / 410	100	1140	3/4	208, 230 or 460	3	65 1/2"	30 1/2"	58"	1"	1"	1/2"
203	780 / 890	50	1140	3/4	208, 230 or 460	3	65 1/2"	30 1/2"	58"	1 1/2"	1"	1/2"
204	700 / 870	100	1140	1 1/2	208, 230 or 460	3	65 1/2"	30 1/2"	58"	1 1/2"	1 1/2"	3/4"
205	1100 / 1300	50	1140	1 1/2	208, 230 or 460	3	65 1/2"	30 1/2"	58"	2"	1 1/2"	1 1/4"
206	1000 / 1200	100	1140	2	208, 230 or 460	3	65 1/2"	30 1/2"	58"	2"	1 1/2"	1"

Pump set ratings are nominal at pressures shown with a maximum 10" Hg vacuum at pump inlet

Ordering Information

Specify the pump set catalog number as follows:

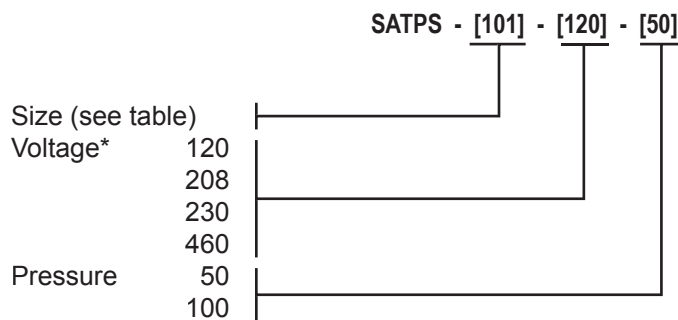

* Pump Set sizes 101 through 103 are single phase only, sizes 104 through 206 are three phase only.

Consult Factory for custom sizes

Optional Features	Catalog Number
Duplex Strainer in lieu of two simplex strainers	add "-D" suffix

SEMI-AUTOMATIC FUEL OIL TRANSFER PUMP SET

Suggested Specifications

1. Piping And Mounting

Provide a duplex pump and straining set that is factory assembled with components piped and mounted on a continuously welded steel plate containment basin with 3" steel side rails. Provide a ½" containment basin plugged drain connection. The basin shall be sized to contain (capture) potential leaks from all factory installed piping and components. Pipe shall be schedule 40 ASTM A-53 Grade "A" with ANSI B16.3 Class 150 malleable iron threaded fittings. Fuel Oil Transfer Pump and Straining Set shall be Preferred Utilities Mfg. Corp. Danbury, CT Model SATPS-LO-___ rated at ___GPH of (No. 2), (No. 4), (Diesel) oil against a discharge pressure of ___psig.

2. Positive Displacement Pumps

Provide and mount two (2) positive displacement rotary type pumps with cast iron housing and self-adjusting mechanical seals. Pumps that have aluminum, brass, or bronze housings or rotors are not acceptable. Packing gland equipped pumps, close-coupled pumps, carbonator shaft mounted pumps or centrifugal pumps are not acceptable.

3. Motors

Provide and mount two (2) open drip proof, rigid base, standard NEMA frame motors. Pump and motor assemblies shall be factory assembled on a structural steel channel. Rotating parts shall have a steel OSHA guard.

4. Pump Isolation and Check Valves

Provide and mount four (4) pump isolation valves. Locate one (1) valve on the suction and discharge side of each pump. Isolation valves must allow off-line pump maintenance without system loss of availability. Isolation valves shall be ball type valves to provide full flow while open and positive shutoff when closed. Additionally, two (2) check valves shall be provided and mounted, one (1) located on the discharge of each pump.

5. Fuel Oil Strainer

Provide and mount two (2) simplex strainers with 40 mesh baskets, one (1) located on the suction side of each pump.

6. Vibration Reduction For Fuel System Life Extension

Careful dampening of positive displacement pump vibration is vital to the long life of the pumps, motors, control switches and entire fuel handling system. Pumps shall be connected to the piping via stainless steel flexible metallic braided jackets. Additionally, the pump and motor shall be connected via an elastomeric jaw type flexible coupling.

7. Relief Valves

Provide and mount two (2) relief valves sized to relieve the full outlet flow of the pump without causing the pump motor to overload or any component's pressure rating to be exceeded if the discharge is inadvertently valved off. Relief valves must be externally mounted from the pumps and piped to the return line in the field according to NFPA 30. Pump internal relief valves shall not be accepted. Relief valves shall be Preferred Model R.

8. Compound And Pressure Gauges

Provide and mount a compound gauge on the suction side of the strainers. The gauge shall read 30" vacuum -15 psig. Provide and mount a pressure gauge on the discharge side of each pump. Gauges selected must provide mid-scale readings under normal operating pressures. Each gauge shall be equipped with an isolation ball valve.

9. Control Cabinet

Provide a completely pre-wired and factory tested control cabinet to ensure job site reliability. The pump set and control cabinet shall be the product of one manufacturer for single source responsibility. The control cabinet shall be constructed to NEMA 12/13 standards. Doors shall be fully gasketed with a turned edge, piano hinges, and a three point lockable latching mechanism. Cabinet interior shall be primed and finished in a white gloss, chemical resistant enamel. Cabinet exterior shall be primed and finished in durable, chemical resistant, textured gray enamel, suitable for industrial environments.

All control wiring shall be terminated at a numbered terminal strip to facilitate field connections to remote equipment. All switches shall have maintained contacts. All cabinet front devices shall be identified by black phenolic labels with engraved white lettering. Cabinet shall consist of, but not be limited to, the following:

1. Magnetic motor starters with overload protection
2. Motor circuit breakers
3. "Hand-off-Auto" switch for each pump
4. Pump Selector Switch for selection of Lead Pump
5. Power on Indicating light
6. Pump running Indicating lights

10. Quality Assurance

The Control Cabinet shall be manufactured and labeled in accordance with UL508A (CSA C22.2 #14 for use in Canada). Simply supplying UL recognized individual components is not sufficient. The assembled control cabinet, as a whole, must be inspected for proper wiring methods, fusing, etc., and must be labeled as conforming to UL508A. Inspection and labeling shall be supervised by UL or other OSHA approved Nationally Recognized Test Lab (NRTL). The system must be manufactured by a nationally recognized Trade Union (I.B.E.W. or similar trade union). Lack of an NRTL certified UL508A wiring methods inspection and label or lack of a Trade Union label will be grounds for rejection.

11. Factory Testing

Pump Sets must be fully tested prior to shipment. Testing shall include both a pressure and vacuum testing period. First, the complete pump set shall be pressure tested to rated pressure using an air pressure source. The test shall confirm that the pump set piping system can maintain rated pressure for 4 hours. Next, the complete pump set shall be brought to a vacuum greater than 25" Hg. The test shall confirm that the pump set piping system can maintain vacuum for 4 hours. Following a pressure and vacuum test the pump set shall be given a full operational test. The pump set shall be connected to a fuel oil supply and return. The pump set shall be operated normally. Motor amps shall be noted at no load and full load for each motor. The motor amps shall be within 10% of rated motor amps. During the test, the relief valve shall be set and tested. Operation of pump set instrumentation shall be tested.

A copy of the test procedures shall be sent to the consulting engineer and owner. The owners and or the consulting engineer at their discretion shall observe this and all other tests. A certificate of factory testing, together with a copy of the wiring diagram and arrangement diagrams shall be placed in the control cabinet prior to shipment.